

N

INSTRUCTION MANUAL

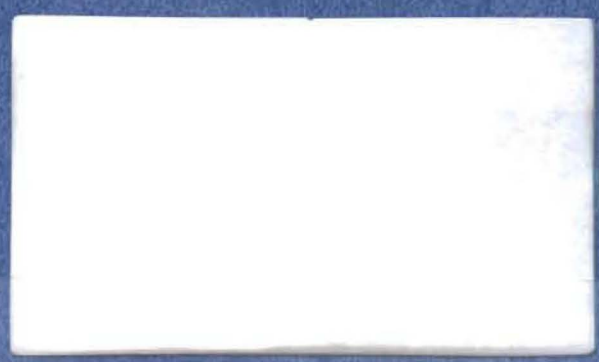

MANUFACTURERS OF CATHODE-RAY OSCILLOSCOPES

NOTE

You will find references to a separate Parts List and Schematic Diagram book in this manual. For greater convenience the parts list and diagrams are now bound into the manual. You will find them at the back of the manual.

INSTRUCTION MANUAL

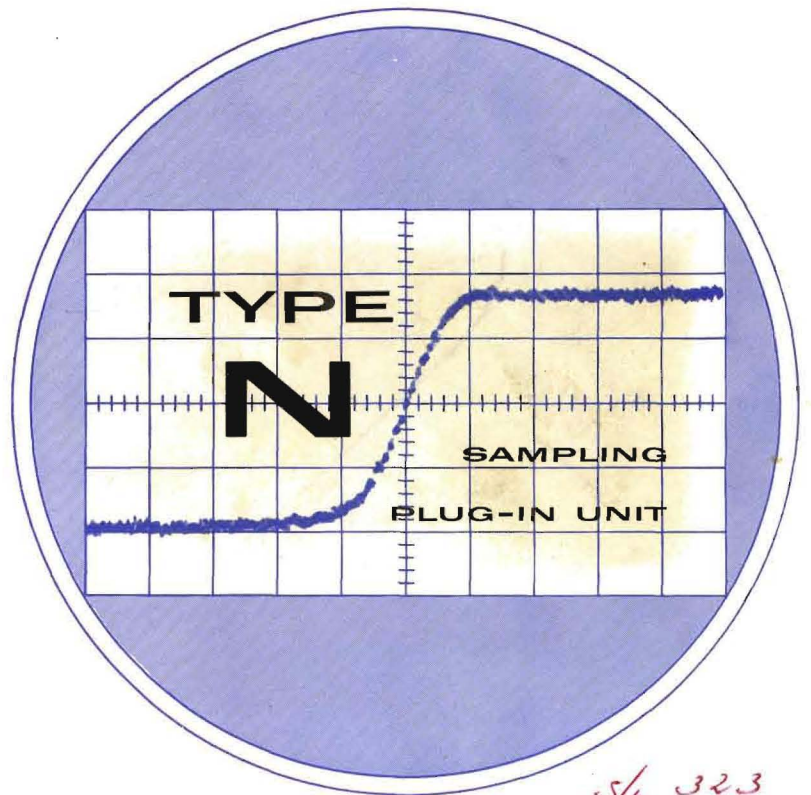

s/n 323

S. W. Millikan Way • P. O. Box 500 • Beaverton, Oregon • Phone MI 4-0161 • Cables: Tektronix



WARRANTY

All Tektronix instruments are warranted against defective materials and workmanship for one year. Tektronix transformers, manufactured in our own plant, are warranted for the life of the instrument.

Any questions with respect to the warranty mentioned above should be taken up with your Tektronix Field Engineer.

Tektronix repair and replacement-part service is geared directly to the field, therefore all requests for repairs and replacement parts should be directed to the Tektronix Field Office or Representative in your area. This procedure will assure you the fastest possible service. Please include the instrument Type and Serial number with all requests for parts or service.

Specifications and price change privileges reserved.

Copyright © 1960 by Tektronix, Inc., Beaverton, Oregon. Printed in the United States of America. All rights reserved. Contents of this publication may not be reproduced in any form without permission of the copyright owner.



CONTENTS

- Section 1 Specifications**
- Section 2 Operating Instructions**
- Section 3 Applications**
- Section 4 Circuit Description**
- Section 5 Maintenance**
- Section 6 Calibration Procedure**
- Section 7 Accessories Section**

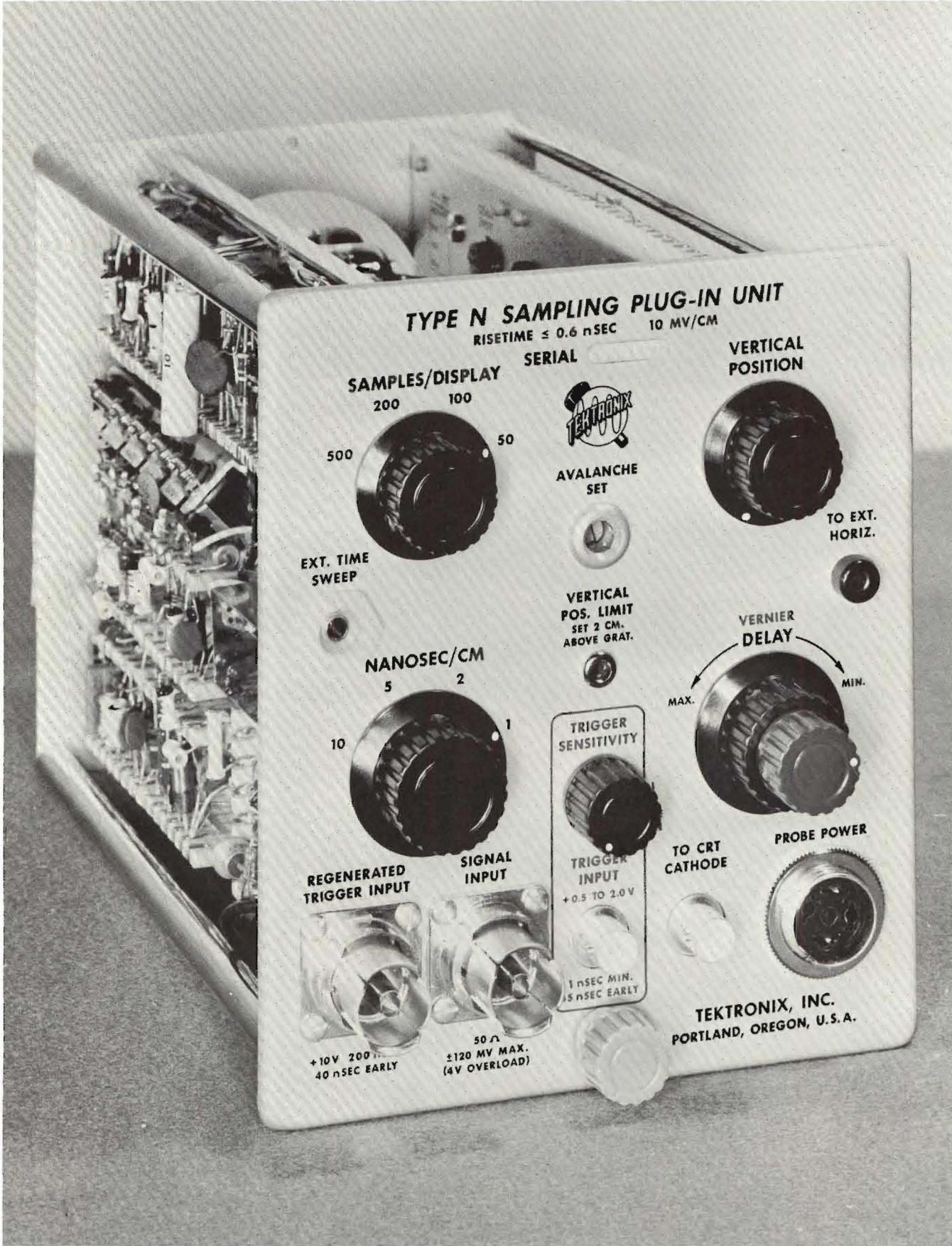

Type N

SPECIFICATIONS

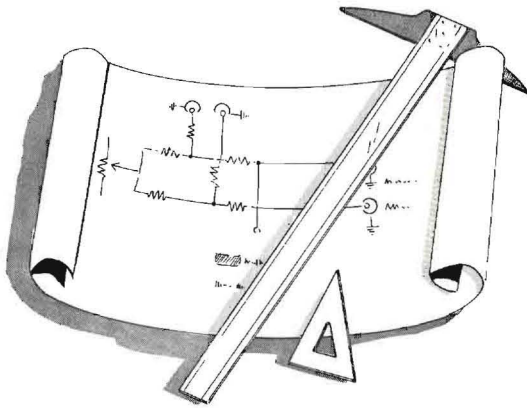
**General Information**

The Type N Sampling Unit is designed for use with Tektronix Type N 530-, 540-, 550-, and 580-Series Oscilloscopes. (With the Type 580-Series Oscilloscopes it is necessary to use a Type 81 Plug-In Adapter.) The sampling system thus formed permits the display of repetitive signals with fractional nanosecond (10^{-9} second or nsec) risetimes. By taking successive samples at a slightly later time at each recurrence of the pulse under observation, the Type N reconstructs the pulse on a relatively long time base.

Specifications**Risetime**

0.6 nsec (corresponding to approx. 600 mc).

Input Impedance

50 ohms.

Sensitivity

10 mv/cm (2 mv or less noise).

Dynamic Range

± 120 mv minimum linear range before overdriving occurs; accidental overload of ± 4 volts is permissible.

Equivalent Sweep Times

1, 2, 5, and 10 nsec/cm (with X10 magnifier: 100, 200, 500, 1000 picosec/cm).

Samples per Display

50, 100, 200, and 500.

Delay Range

200 nsec less the period of the display.

Sampling Repetition Rate

50 cps to 100 kc.

Triggering Signal Requirements

If applied to the TRIGGER INPUT connector, 0.5 to 2 volts, 1 nsec or more duration, 45 nsec in advance of the signal. Repetition rate 50 cps to 50 mc.

If applied to the REGENERATED TRIGGER INPUT connector, approximately 10 volts, 225 nsec duration, 40 nsec in advance of the signal. Repetition rate 50 cps to 100 kc.

Power Supplies

Transistor regulated -20 - and $+20$ -volt supplies.

Mechanical

Construction—Aluminum alloy chassis.

Finish—Photoetched, anodized panel.

Weight—7 lbs.

Accessories

1—External Horizontal cable, 18" long, (012-054).

1—Crt unblanking cable, 60" long, (012-052).

2—1-nsec cables, RG-58A/U, pigtails, 8" long, (017-503).

1—5-nsec cable, RG-8A/U, 40" long, (017-502).

1—10-nsec cable, RG-58A/U, 80" long, (017-501).

1—X2 attenuator, 50 Ω , (017-003).

1—X5 attenuator, 50 Ω , (017-002).

1—X10 attenuator, 50 Ω , (017-001).

1—3-wire power cord.

1—3-wire adapter.

1—Instruction Manual.

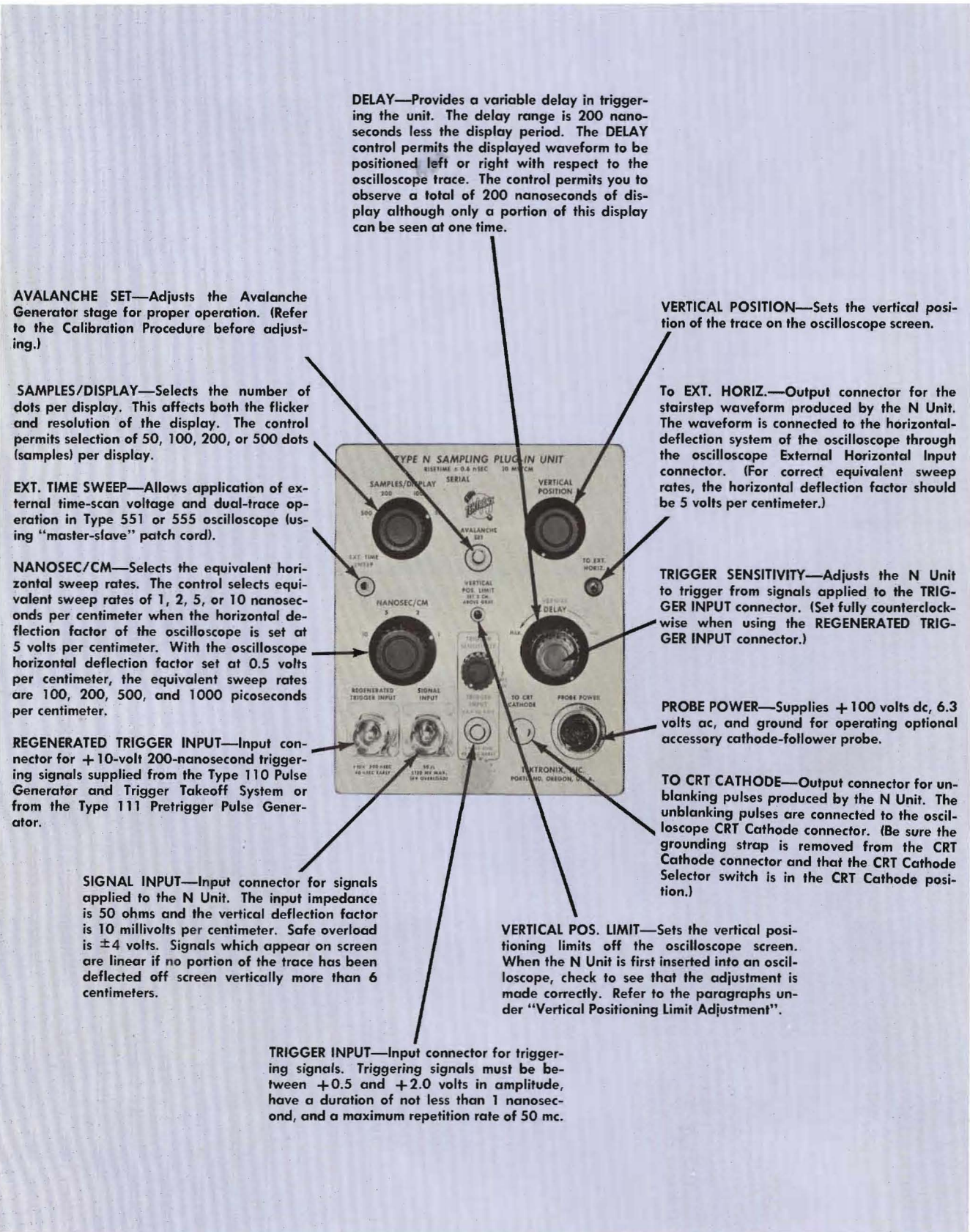

DELAY—Provides a variable delay in triggering the unit. The delay range is 200 nanoseconds less the display period. The DELAY control permits the displayed waveform to be positioned left or right with respect to the oscilloscope trace. The control permits you to observe a total of 200 nanoseconds of display although only a portion of this display can be seen at one time.

AVALANCHE SET—Adjusts the Avalanche Generator stage for proper operation. (Refer to the Calibration Procedure before adjusting.)

SAMPLES/DISPLAY—Selects the number of dots per display. This affects both the flicker and resolution of the display. The control permits selection of 50, 100, 200, or 500 dots (samples) per display.

EXT. TIME SWEEP—Allows application of external time-scan voltage and dual-trace operation in Type 551 or 555 oscilloscope (using "master-slave" patch cord).

NANOSEC/CM—Selects the equivalent horizontal sweep rates. The control selects equivalent sweep rates of 1, 2, 5, or 10 nanoseconds per centimeter when the horizontal deflection factor of the oscilloscope is set at 5 volts per centimeter. With the oscilloscope horizontal deflection factor set at 0.5 volts per centimeter, the equivalent sweep rates are 100, 200, 500, and 1000 picoseconds per centimeter.

REGENERATED TRIGGER INPUT—Input connector for +10-volt 200-nanosecond triggering signals supplied from the Type 110 Pulse Generator and Trigger Takeoff System or from the Type 111 Pretrigger Pulse Generator.

SIGNAL INPUT—Input connector for signals applied to the N Unit. The input impedance is 50 ohms and the vertical deflection factor is 10 millivolts per centimeter. Safe overload is ± 4 volts. Signals which appear on screen are linear if no portion of the trace has been deflected off screen vertically more than 6 centimeters.

TRIGGER INPUT—Input connector for triggering signals. Triggering signals must be between +0.5 and +2.0 volts in amplitude, have a duration of not less than 1 nanosecond, and a maximum repetition rate of 50 mc.

VERTICAL POSITION—Sets the vertical position of the trace on the oscilloscope screen.

To EXT. HORIZ.—Output connector for the stairstep waveform produced by the N Unit. The waveform is connected to the horizontal-deflection system of the oscilloscope through the oscilloscope External Horizontal Input connector. (For correct equivalent sweep rates, the horizontal deflection factor should be 5 volts per centimeter.)

TRIGGER SENSITIVITY—Adjusts the N Unit to trigger from signals applied to the TRIGGER INPUT connector. (Set fully counterclockwise when using the REGENERATED TRIGGER INPUT connector.)

PROBE POWER—Supplies +100 volts dc, 6.3 volts ac, and ground for operating optional accessory cathode-follower probe.

TO CRT CATHODE—Output connector for unblanking pulses produced by the N Unit. The unblanking pulses are connected to the oscilloscope CRT Cathode connector. (Be sure the grounding strap is removed from the CRT Cathode connector and that the CRT Cathode Selector switch is in the CRT Cathode position.)

VERTICAL POS. LIMIT—Sets the vertical positioning limits off the oscilloscope screen. When the N Unit is first inserted into an oscilloscope, check to see that the adjustment is made correctly. Refer to the paragraphs under "Vertical Positioning Limit Adjustment".

Fig. 2-1. Functions of the Type N Unit front-panel controls and connectors.

SECTION 2

OPERATING INSTRUCTIONS

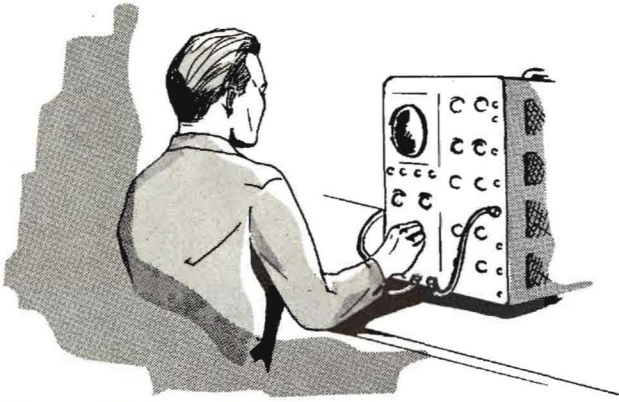

General Information

The Type N Unit is a special vertical plug-in unit which converts any Type 530-, 540-, or 550-series oscilloscope (also the Type 580-series with an adapter) to a sampling-type oscilloscope. The sampling system thus formed allows you to easily observe waveforms which far exceed the risetime capabilities of the oscilloscope alone. The overall equivalent risetime of the sampling system is approximately 0.6 nanosecond (nsec).

The sampling system formed by the combination of the N Unit and a conventional oscilloscope is quite different in operation from normal oscilloscope systems. A conventional oscilloscope system traces out a virtually continuous picture of waveforms applied to the oscilloscope input; a complete display is formed for each input waveform. The sampling system, however, samples the input waveform at successively later points in relative time on a large number of input pulses. From this sampling process, a series of signal samples is obtained. The amplitude of each signal sample is proportional to the amplitude of the input signal during the short time the sample is made. Input waveforms are then reconstructed on the screen of the oscilloscope, as a series of dots, from these signal samples. The oscilloscope bandpass required to pass the "time stretched" signal samples is much less than the bandpass which would be required to pass the original input signal. The relatively low bandpass requirements of the oscilloscope in the sampling system permit much higher vertical sensitivities than those easily ob-

tainable in conventional systems, for the same risetime. The apparent sweep speed, for a given writing rate, can also be made much faster, since the CRT spot is stationary during display, and moves only a short distance between signal repetition.

Cabling Considerations

The N Unit uses BNC and GR 50-ohm connectors on the front panel. The different connectors aid in connecting the unit properly to the oscilloscope and the signal source. If the cables supplied with the N Unit are used, it is unlikely that you will connect them improperly.

The N Unit is frequently used with the Type 110 Pulse Generator or the Type 111 Pretrigger Pulse Generator. Each of these units is designed for 50-ohm inputs and outputs, and it is important that 50-ohm cables are used with the units. This is particularly true of all input signal connections. If it is necessary to use cables with characteristic impedances other than 50 ohms, suitable impedance matching devices must be used. If proper impedance matches are not made, reflections and standing waves in the cables will result in distortion of the displayed waveform. In general, it may be stated that the same cabling precautions must be observed with the N Unit as with any other high frequency equipment.

Another factor which must be considered when connecting the input signal to the N Unit is the finite time delay produced by the cables. This delay is important in the operation of the N Unit. If an improper delay of the signal

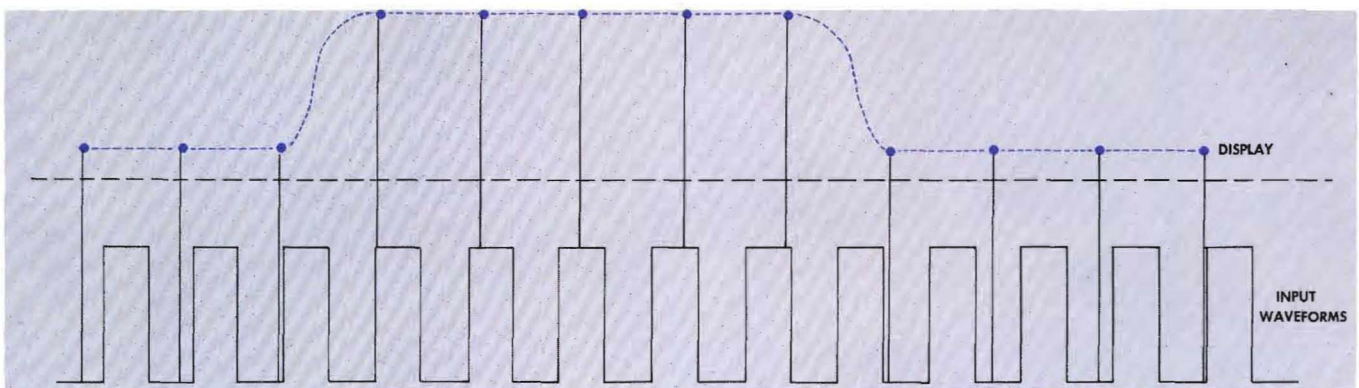

Fig. 2-2. Displaying input waveforms by means of the sampling technique. In the illustration, a series of sampling pulses is superimposed on the input waveforms. These sampling pulses, and not the actual input signal, are applied to the oscilloscope. At the peak of each sampling pulse the crt of the oscilloscope is unblanked and a spot appears. A large number of such spots forms the oscilloscope display. Using the Type N Unit, the number of spots per display is from 50 to 500.

Operating Instructions — Type N

is introduced, it may not be possible to observe the waveform on the oscilloscope. Selection of the necessary signal delay is discussed in this section under "Connecting the Input Signal" and "Triggering the Sweep".

Connecting the N Unit to the Oscilloscope

To connect the N Unit to the oscilloscope, it is first necessary to insert the unit into the plug-in compartment of the oscilloscope. Next, the sweep generated by the N Unit must be connected to the horizontal-deflection system of the oscilloscope. Finally, the unblanking pulses generated by the N Unit must be connected to the CRT circuit of the oscilloscope. These connections are made as follows:

Insert the N Unit into the plug-in compartment of the oscilloscope and tighten the locking control. Turn the oscilloscope Intensity control fully counterclockwise and switch on the oscilloscope power. Connect a 50-ohm coaxial cable to the SIGNAL INPUT connector and terminate the other end of the cable with 50 ohms. Rotate the N Unit TRIGGER SENSITIVITY control fully clockwise to the FREE RUN position and allow a brief warmup period. Turn up the intensity and use the HORIZONTAL POSITION and VERTICAL POSITION controls to move the spot on the screen.

Before connecting the N Unit sweep to the horizontal deflection system of the oscilloscope, you must first calibrate the horizontal deflection system to 5 volts per major graticule division. To do this, connect 50-volt square waves from the calibrator to the External Horizontal Input connector of the oscilloscope. Set the Horizontal Display switch at External and the attenuator at X10. Adjust the variable attenuator for exactly 10 divisions of horizontal deflection. Reposition the trace so that it starts at the center of the screen. Disconnect the calibrator signal. Next connect the special sweep cable from the TO EXT. HORIZ. connector on the N Unit to the External Horizontal Input connector of the oscilloscope. This connects the sweep generated in the N Unit to the horizontal deflection system of the oscilloscope.

To connect the unblanking pulses from the N Unit to the CRT Circuit of the oscilloscope, first disconnect the ground strap from the CRT Cathode Connector at the rear of the oscilloscope. Then, connect the special unblanking pulse cable from the TO CRT CATHODE connector on the N Unit to the Ground and CRT Cathode connectors at the rear of the oscilloscope. (If using a Type 550-series oscilloscope, be sure to read the CAUTION note on page 2-8 before connecting the crt unblanking cable.) If your oscilloscope has a CRT Cathode selector switch, place this switch in the CRT Cathode position.

Connecting the Triggering Signal

The N Unit requires an external triggering signal prior to each input signal pulse. The triggering signal must be applied to either the TRIGGER INPUT or REGENERATED TRIGGER INPUT connectors. Triggering signals applied to the TRIGGER INPUT connector must have an amplitude between +0.5 and +2.0 volts, a duration greater than 1 nanosecond, and a maximum repetition rate of 50 mc. Signals applied to the REGENERATED TRIGGER INPUT connector must have an amplitude between +7 and 15 volts, a risetime less than 4 nanoseconds, a duration of 225 to 250 nanoseconds, and a maximum repetition rate of approximately 100 kc. Special circuits are required to produce the input to the REGENERATED

TRIGGER INPUT connector. These circuits are incorporated in the Type 110 Pulse Generator and Trigger Takeoff System, and the Type 111 Pretrigger Pulse Generator.

If a suitable triggering signal is not available, you can use the Type 110 to obtain a triggering signal directly from the signal to be observed. The 110 trigger takeoff system converts approximately 4% of the signal energy into a triggering waveform. Since the impedance of the triggering and signal systems is the same (50 ohms), 4% of the signal energy yields a trigger which is 20% of the signal voltage in amplitude. The triggering signal is then attenuated, amplified, and/or inverted, as required, in the Type 110, until a signal is obtained which will allow the N Unit to be triggered. Separate outputs from the 110 provide triggering signals to either the TRIGGER INPUT or REGENERATED TRIGGER INPUT connectors on the N Unit. This is discussed in greater detail under "Triggering the Sweep".

If neither the 110 nor the 111 is used, connect the triggering signal directly to the Type N TRIGGER INPUT connector. Triggering is then controlled by the N Unit. If the 110 is used, connect the signal to be observed to the SIG. IN FOR TRIG. TAKEOFF connector on the back panel. The signal from the SIGNAL OUT 98% connector of the 110 should then be applied to the SIGNAL INPUT connector of the N Unit through a 60-nsec delay cable. The Type 113 Delay Cable is suitable for this purpose. If the 110 is used, triggering may be controlled by either the N Unit or the 110 depending on whether the triggering signal is obtained from the REGENERATED TRIG. OUT 50 Ω or EXTERNAL TRIG. OUT 50 Ω connector. Triggering signals from the REGENERATED TRIG. OUT 50 Ω connector of the 110 should be connected to the REGENERATED TRIGGER INPUT connector of the N Unit. Signals from the EXTERNAL TRIG. OUT 50 Ω connector should be connected to the TRIGGER INPUT connector of the N Unit. Usually the REGENERATED TRIGGER connector will be used. For complete operating instructions for the 110, refer to the Type 110 Instruction Manual. Cable connections are shown in Figure 2-3.

The Type 111 Pretrigger Pulse Generator supplies its own regenerated trigger output pulse in addition to a signal pulse. If the 111 is used, the regenerated trigger should be applied to the REGENERATED TRIGGER INPUT connector of the N Unit. The signal pulse should be applied to the device under test. The output of the device under test must then be connected to the SIGNAL INPUT connector of the N Unit. The signal pulse output of the 111 can be delayed up to 250 nanoseconds after the triggering signal. This generally eliminates the need for any external delay in the signal path. For complete operating instructions for the 111, refer to the Type 111 Instruction Manual. Cable connections are shown in Figure 2-4.

Connecting the Input Signal

Input signals to the Type N Unit should be connected through 50-ohm cables or suitable impedance matching devices to the SIGNAL INPUT connector. The vertical sensitivity of the N Unit is 10 millivolts per major graticule division. If the signal amplitude is too great, it will be necessary for you to attenuate the signal to a usable level before applying it to the SIGNAL INPUT connector. Three attenuators are supplied with the N Unit. These attenuators have attenuation factors of 2, 5, and 10 when used indivi-

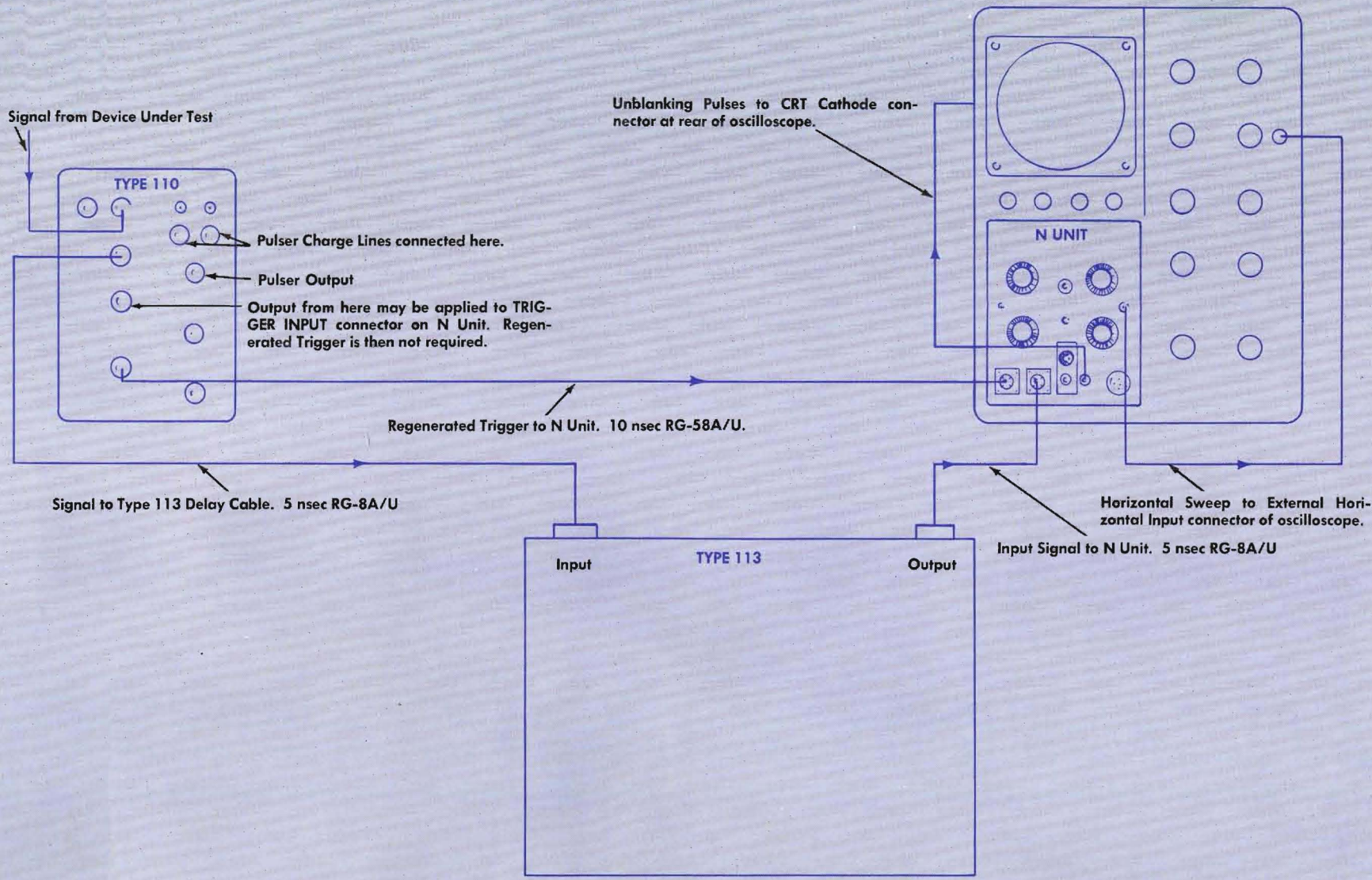

Fig. 2-3. Cable connections for the Type N Unit when used with Type 110 Pulse Generator and Trigger Takeoff System.

Operating Instructions — Type N

dually. By cascading the attenuators, you can attenuate a signal up to 100 times. With 100 times attenuation, the vertical deflection factor is 1 volt per major graticule division. If more attenuation is required, it will be necessary to use additional attenuators. A number of 50-ohm attenuators are available which will operate above 2 gigacycles (2,000 mc). It is important to use attenuators which have at least a 2-gigacycle bandpass to prevent reduction of the sampling system's overall performance.

Triggering signals applied to the Type N Unit must precede the input signal waveforms by approximately 40 nanoseconds. In general, this means that the input signal must be delayed by this amount of time. The amount of delay required will depend on the length of cables and the time relationship of the triggering signal to the input signal. If the proper signal delay is not used, the input waveform will not be displayed on the oscilloscope. The N-Unit DELAY control permits you to search 200 nanoseconds of time. If the waveform occurs in this 200-nanosecond period the DELAY con-

trols can be used to position the waveform on the screen. These controls are used to provide the final vernier delay after the rough delay is determined by the input cabling.

When the Type 111 Pretrigger Pulse Generator is used, a pretrigger occurs 40 to 250 nanoseconds ahead of the pulse output. Because of this time relationship extra delay is seldom required. When the Type 110 Pulse Generator and Trigger Takeoff system is used to derive the triggering signal, 60 nanoseconds of delay is required between the trigger takeoff point and the N Unit. The Tektronix Type 113 Delay Cable can be used to provide the required signal delay. Low losses in the Type 113 permit the full capabilities of the N Unit to be utilized.

In most N-Unit applications, the Type 113 Delay Cable will provide approximately the necessary delay of the input signal. However, when the N Unit is used without the Type 110 or Type 113, it will probably be necessary to determine the exact delay necessary by experiment. The triggering signal to the TRIGGER INPUT connector should ar-

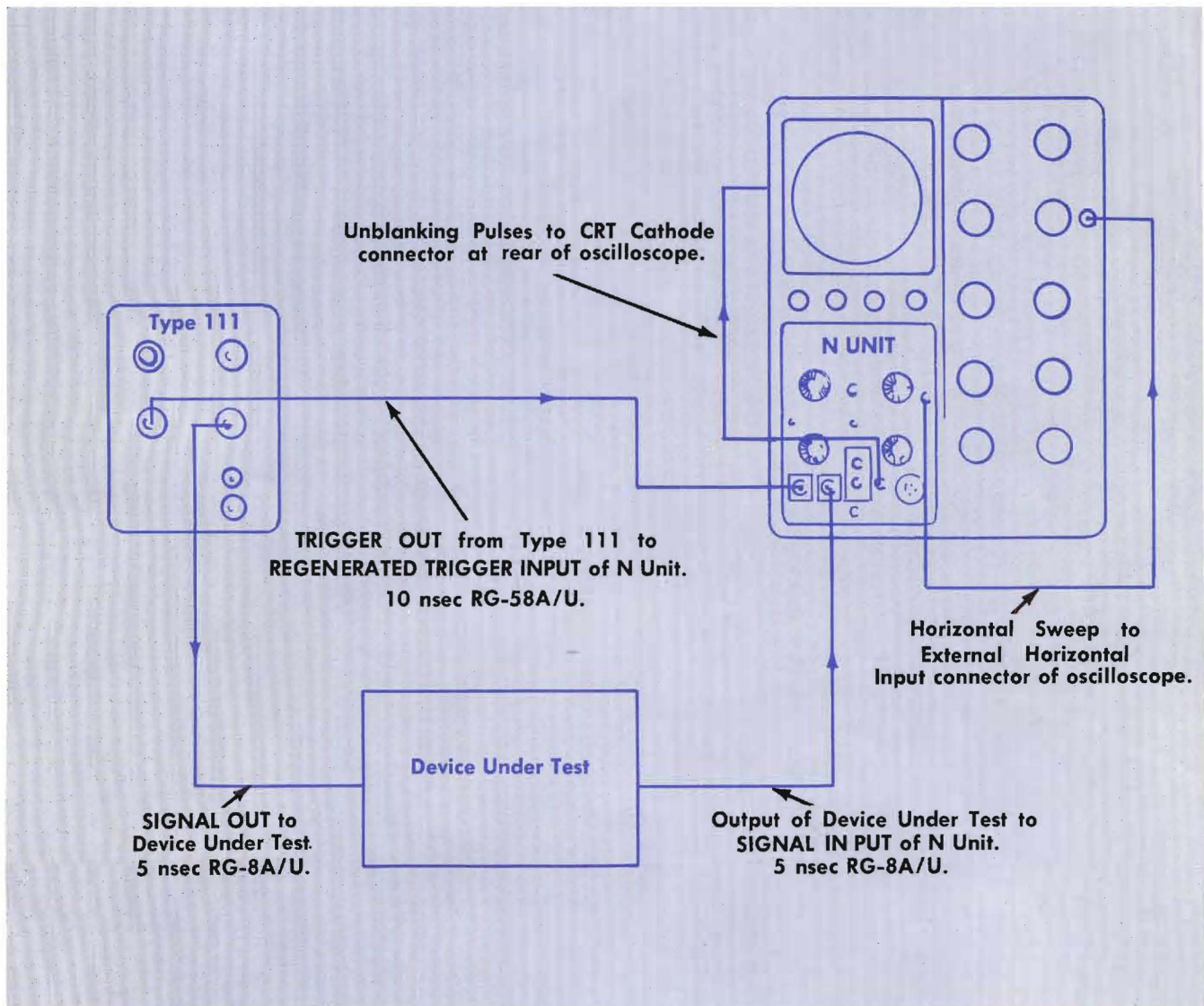

Fig. 2-4. Cable connections for the Type N Unit when used with the Type 111 Pretrigger Pulse Generator.

rive approximately 45 nanoseconds ahead of the input signal. The GR connectors used on the N Unit permit cable lengths to be easily changed, thereby changing the delay time. The delay provided by RG-8A/U cable (or other solid polyethylene dielectric cable) is approximately one nanosecond per 8 inches. If any portion of the input waveform is displayed on the oscilloscope, you can usually determine the amount of delay which must be added or subtracted to display the waveform properly on the screen. This can be determined by the sweep speed and the number of divisions that the display must be moved. If the display must be moved to the left, less delay is required. If the display must be moved to the right, more delay is required. In general, it is usually desirable to use a minimum of time delay in the triggering leads, since this reduces the amount of high quality cable required. The proper delay can be determined only after the sweep is triggered properly and a stable display is obtained. Triggering the sweep is discussed in the following paragraphs.

Triggering the Type N Unit

Each time the Type N Unit is triggered, a sample is made of the input waveform, the sample is displayed, and the spot moves a step horizontally across the screen. This sequence occurs each time the unit is triggered. When the unit is triggered properly, the continuous sampling and horizontal movement of the spot across the screen forms the display.

As described previously, to trigger the Type N Unit you must first connect a triggering signal to either the TRIGGER INPUT or REGENERATED TRIGGER INPUT connector. When triggering signals are applied to the TRIGGER INPUT connector of the N Unit you must adjust the TRIGGER SENSITIVITY control for stable triggered operation.

To adjust the control, first set it fully counterclockwise. Then turn up the intensity of the oscilloscope and slowly rotate the TRIGGER SENSITIVITY control clockwise until a steady trace appears on the crt. (If the oscilloscope Horizontal position neon indicators flash, but no trace appears, adjust the VERTICAL POSITION control to locate the trace.) At its final setting, the TRIGGER SENSITIVITY control should be as far clockwise as possible without free-running the sweep. When triggering signals are applied to the REGENERATED TRIGGER INPUT connector, the TRIGGER SENSITIVITY control on the N Unit is not used. The unit under these conditions operates automatically each time a Regenerated Triggering Pulse is applied. When the TRIGGER SENSITIVITY control is not used, it should be rotated fully counterclockwise to prevent spurious operation of the N Unit.

If the Type 110 unit supplies the regenerated triggering signal to the N Unit, triggering is controlled completely by the 110. The TRIGGER SENSITIVITY control on the 110 is adjusted in exactly the same manner as the TRIGGER SENSITIVITY control on the N Unit. The regenerator circuit of the 110 unit permits you to trigger the N Unit from signals with repetition rates as high as 100 mc. The equivalent regenerator in the N Unit only permits triggering at frequencies up to 50 mc. Otherwise there is no particular advantage in using the regenerator circuit of the 110 over that of the N Unit.

When the Type 111 Pretrigger Pulse Generator is used, no triggering adjustments are necessary except to turn the

TRIGGER SENSITIVITY control of the N Unit fully counterclockwise. The N Unit is started automatically each time a pulse from the 111 is applied to the REGENERATED TRIGGER INPUT connector of the N Unit.

When the N Unit is triggered properly by any of the methods described, center the trace on the screen with the positioning controls. Set the NANOSEC/CM switch at 10 and the SAMPLES/DISPLAY switch at 50. Check that the waveform is displayed properly on the screen. A fast-rising displayed waveform should start about one centimeter from the left side of the screen when the DELAY control is set fully clockwise. Set the NANOSEC/CM control at 1. If the risetime of the displayed waveform is on the order of 1 or 2 nanoseconds, it should be possible to move the start of the displayed waveform off the right side of the screen.

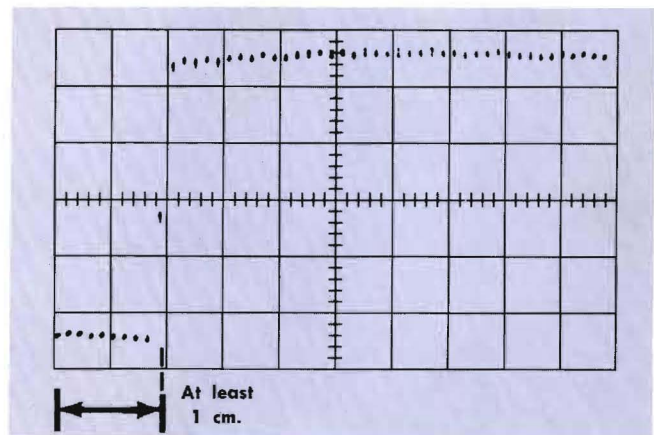

Fig. 2-5. Selecting the proper signal and trigger delays. With a sweep rate of 10 nsec per centimeter and the DELAY control set fully clockwise, a fast-rising pulse should start at least one centimeter from the left side of the oscilloscope screen.

If not, it will be necessary for you to add or subtract delay in the signal or triggering paths by changing the cable lengths. The DELAY control then permits you to position the waveform horizontally with respect to the trace. The proper delay is obtained when the Trigger Input Signal arrives about 45 nanoseconds ahead, or the Regenerated Triggering Signal arrives 40 nanoseconds ahead, of the signal waveform.

If you are using the Type 110 with the N Unit, it is not necessary for you to use an experimental method to obtain the delay required. The delay required between the trigger takeoff of the 110 and the N Unit is known to be approximately 60 nanoseconds. This delay is provided by the Type 113 Delay Cable.

When the Type 111 is used with the N Unit, no delay cable is required. If the waveform does not immediately appear as described previously, set the N Unit DELAY control fully clockwise. Then adjust the DELAY control on the Type 111 until the waveform is displayed properly on the oscilloscope screen. If the waveform does not appear correctly, there is probably an excessive time delay in the signal path (over 160 nsec). Add delay to the trigger leads if the DELAY control on the N Unit does not have sufficient range to display the waveform properly.

Selecting the Equivalent Sweep Rates

The Type N Unit provides equivalent sweep rates of 1, 2, 5 and 10 nsec per centimeter. These sweep rates in turn provide displays 10, 20, 50 and 100 nanoseconds in duration. These sweep rates are sufficiently fast to accurately observe fast rising waveforms within the risetime capabilities of the N Unit. However, if desired, you can obtain equivalent sweep rates of 100, 200 500 and 100 picoseconds per centimeter by placing the External Horizontal Attenuator Switch in the X1 position. (Center the waveform horizontally on the graticule before moving the switch from the X10 position to the X1 position to prevent it from moving off the screen. If the waveform does move off the screen horizontally, it must be positioned back onto the screen with the DELAY controls, not with the oscilloscope HORIZONTAL POSITION control.)

If you require slower sweep rates than those provided by the Type N Unit, you can remove the N Unit from the oscilloscope and substitute another vertical plug-in unit, such as the Type L or Type K. The internal sweep system of the oscilloscope can then be used to provide the sweep rate required.

Selection of the equivalent sweep rate is made with the NANOSECOND/CM switch. Increasing the sweep rate increases the horizontal size of the waveform displayed. Conversely, decreasing the sweep rate decreases the horizontal size of the displayed waveform. Your selection of sweep rate will depend on the type of waveform you wish to observe and on the portion of the waveform you are particularly interested in.

In the N Unit, the sweep is not formed by the continuous movement of the spot across the screen. Instead the beam makes a movement and unblanks each time the unit is triggered and a sample made. When the NANOSECOND/CM control is set at 1, the spot does not actually move 1 centimeter across the screen each nanosecond. How-

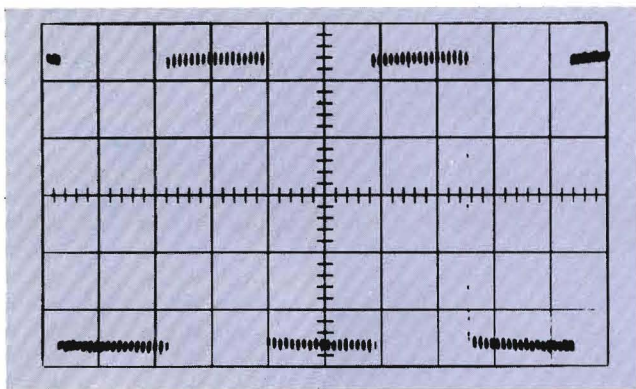

Fig. 2-6. Waveform due to the true sweep time per centimeter rather than equivalent sweep time per centimeter. This illustrates one type of false display that can be obtained using a sampling oscilloscope system. In this case the oscilloscope calibrator waveform is displayed with the N Unit NANOSEC/CM control set at 1. This gives an apparently phenomenal risetime to the calibrator waveform. This false display is due to the triggering of the Type N Unit at some multiple of the calibrator frequency. False displays can easily be detected through use of the SAMPLES/DISPLAY control.

ever, the display obtained is the same as though the spot did move at this rate. One nanosecond per centimeter is then the equivalent sweep rate rather than the actual sweep rate. The equivalent sweep rates of the N Unit are accurate to within 5%. Accurate time measurements in the order of nanoseconds can be made directly from the oscilloscope display. A Timing Standard is available for accurate calibration of sweep rates.

Under certain conditions it is possible to get a false display when using sampling type instruments. This is due to the way a sampling system operates. A false display obtained while using the N Unit can always be detected quite easily, however, by rotating the SAMPLES/DISPLAY control. This should change nothing but the number of dots per centimeter. If the waveform changes its apparent repetition rate, or disappears, as the number of samples per display is changed, the display is false and should be ignored. False displays usually fall into one of two categories. One type of false display may occur when there is an insufficient number of dots per display to reproduce all of the information. (For example, a 1-gigacycle damped sine wave train on the 10-nsec/cm sweep rate, at 50 dots per display, might look like a 100-mc train. In this case, switching to 500 dots per display would show up the error). The other type of false display occurs when the N Unit is triggered at some multiple of the signal repetition rate. (A false display of this type would be obtained at 100 dots per display if the 1-kc oscilloscope calibrator waveform is used as the signal source while the N Unit is triggered at 100 kc by the Type 111.) With either type of false display, you can usually obtain the correct display with some other setting of the SAMPLES/DISPLAY switch.

Selecting the Number of Samples Per Display

You will recall that each time the N Unit is triggered a sampling of the input waveform is made. The oscilloscope display is formed from the combination of a large number of such samples. The number of samples required to form a complete oscilloscope display is determined by the setting of the SAMPLES/DISPLAY switch. This control allows you to select 50, 100, 200 or 500 samples per display. Since at least one triggering waveform is required for each sample taken, from 50 to 500 or more triggering waveforms are required to form a complete display. The greater the number of samples per display the more nearly continuous is the waveform displayed on the screen. With 500 samples per display, the display is formed by 50 dots per centimeter horizontally. This appears to be nearly a continuous trace except at the leading and trailing edges of fast rising and falling pulses. If the repetition rate of the waveform being observed is quite high, you will probably want to use 500 samples per display.

At any particular triggering repetition rate, the number of displays per second for 50 samples per display is 10 times as great as for 500 samples per second. For triggering rates up to 100 kc, the average number of displays per second is the average triggering repetition rate divided by the number of samples per display (ignoring the effects of retrace time). Consequently, at low trigger repetition rates, less flicker of the display is obtained with 50 samples per display than with 500 samples per display. At the same time, the display is much coarser. At very low trigger re-

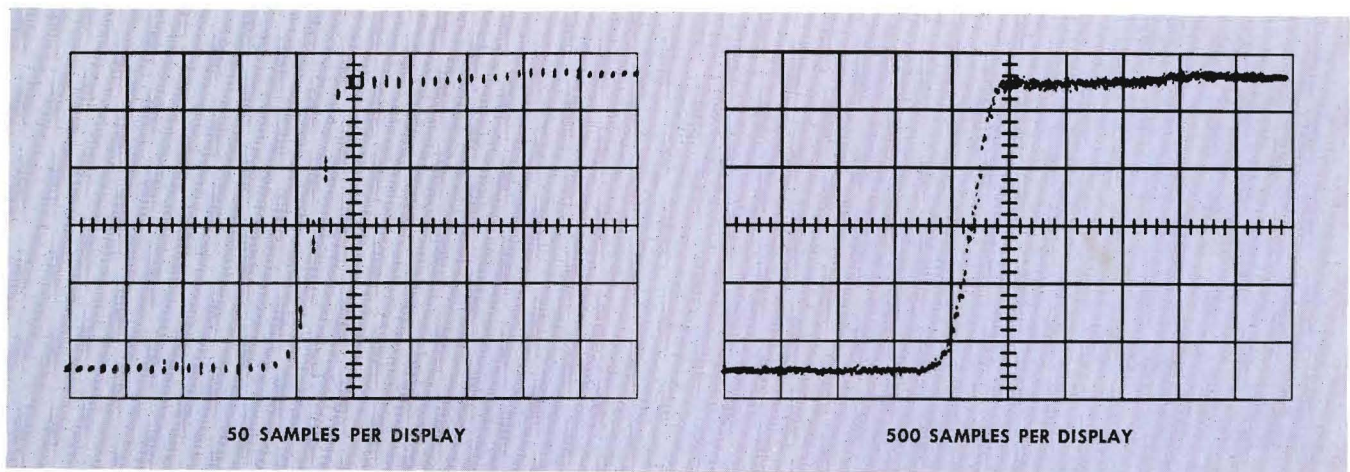

Fig. 2-7. Comparison of the trace continuity obtained with 50 and 500 samples per display.

petition rates, it may be necessary to use 50 samples per display in order to have a high enough display repetition rate to see the trace in its entirety. This is due to the low persistence of the crt phosphors. At low trigger repetition rates, the higher flicker rate at 50 samples per display makes it more convenient to manipulate the waveform on the display (with the Positioning controls, for example).

In general, you will set the SAMPLES/DISPLAY switch to obtain sufficient continuity. The setting is a compromise between flicker rate and coarseness of the display at low trigger repetition rates.

The dots on the oscilloscope display can actually be used as equivalent time markers. These will aid in making time measurements directly from the oscilloscope display. The SAMPLES/DISPLAY switch controls the number of samples per display, and consequently the equivalent time spacing between dots. For example, at 1 nanosecond per centimeter and 100 samples per display, the equivalent time between dots is 100 picoseconds. Under these circumstances, there are 10 dots per centimeter. If you place the oscilloscope's External Horizontal Attenuator switch in the X1 position, you can expand the display horizontally by a factor of 10. There is then 1 dot per centimeter, making it easy to count the number of dots. Using this method, it is relatively easy to accurately measure the 600-picosecond risetime of the N Unit. To measure the N-Unit's risetime, however, you must use a signal pulse and delay cable combination with a risetime well under 250 picoseconds.

Vertical Positioning Limit Adjustment

Occasionally when you are using the N Unit, you may find that the VERTICAL POSITION control has insufficient range of adjustment. This is indicated by the inability to position the trace off both the top and bottom of the screen, or by extreme vertical nonlinearity as the trace is moved up and down the screen with the VERTICAL POSITION control. This condition may be corrected by adjustment of the VERTICAL POS. LIMIT control. (The AV-ALANCHE SET control should not be adjusted unless the

need for calibration has been determined.)

To make the adjustment, first remove all signals from the unit and free-run the sweep by rotating the TRIGGER SENSITIVITY control fully clockwise. Terminate the SIGNAL INPUT connector in 50 ohms. This can be done by connecting a 50-ohm 10X attenuator to the SIGNAL INPUT connector. Adjust the VERTICAL POS. LIMIT control so that the upper positioning limit is on the screen of the oscilloscope. The upper positioning limit is reached when clockwise rotation of the VERTICAL POSITION control no longer moves the oscilloscope trace up. Using the VERTICAL POS. LIMIT control, move the upper positioning limit to the top of the graticule. Then, use the VERTICAL POSITION control to move the trace down 2 centimeters. Now move the trace to the top of the screen with the VERTICAL POS. LIMIT control. This sets the upper vertical positioning limit 2 centimeters above the top of the graticule. You should now be able to position the trace smoothly from the bottom of the screen to the top with no "limiting" action evident.

If the white indicator dot on the VERTICAL POSITION control is more than 15° from straight up when the trace is vertically centered (with SIGNAL INPUT terminated and no dc applied), then the Vertical Channel should be recalibrated (see Section 6).

NOTE

Type 532 and Type 536 Oscilloscopes have graticules with more than 6 vertical divisions. When setting the VERTICAL POS. LIMIT control with these oscilloscopes, consider the top of the graticule to be 3 major divisions above the center-line.

Dual-Trace Operation

Dual-trace sampling system operation can be obtained with two Type N Units used with a Tektronix Type 551 or Type 555 Oscilloscope. To obtain synchronized operation of the two Type N Units, connect a "master-slave" patch cord

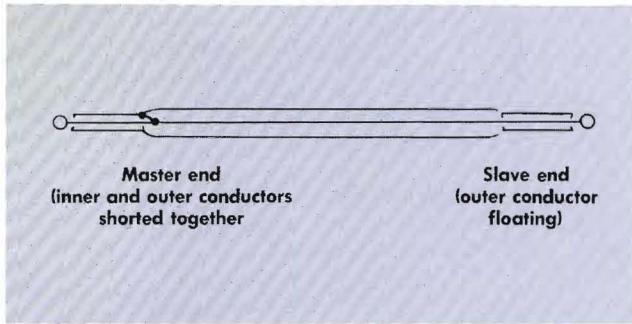

Fig. 2-8. "Master-slave" patch cord

from the EXT. TIME SWEEP jack of one to the EXT. TIME SWEEP jack of the other. (The construction of the "master-slave" patch cord is shown in Fig. 2-8. Note that the "master" and "slave" units are determined only by the way the cable is connected.) Connect the horizontal sweep voltage from the TO EXT. HORIZ. connector of the master unit to the HORIZ. INPUT connector on the Type 551 Oscilloscope or to both EXT. HORIZ. INPUT connectors on the Type 555 Oscilloscope. (The horizontal sweep voltage from the slave unit is not used.) With the Type 551 Oscilloscope, apply the cathode unblanking signal from the master unit to the crt cathode connector at the rear of the instrument. With the Type 555 Oscilloscope, apply the cathode unblanking signals from both units to their respective crt cathode connectors. Be sure that the crt grounding straps are removed before making connections at the crt cathode connectors.

CAUTION

The spacing between the CATHODE and GND. connectors on the Type 551 and 555 oscilloscopes is different from that between the pins of the crt unblanking cable. When using these instruments, connect only the CATH. pin of the cable to the CATHODE connector on the oscilloscope. It is not necessary to make a ground connection at the rear of the oscilloscope for this operation.

In dual-trace operation, the number of samples per display can be controlled only at the master unit, but the

sweep rates (NANOSEC/CM) and delay of both units can be controlled separately. The input and triggering signals are applied in the normal manner except that the same triggering signal is applied to both units.

In some cases (such as when the sampling units are connected near one another in a given circuit), it may be noticed that the operation of one unit causes spurious signals to appear on the display of the other. This situation can be avoided by operating both units at the same sweep rate and delay setting, or by providing more isolation between the two sampling inputs.

Analog-Recorder Operation

By replacing the staircase sweep in the Type N Unit with an external time-sweep voltage, the Type N Unit can be adapted to drive a recording oscillograph which will record any waveform within the risetime capabilities of the sampling system. For this type of operation, apply a 50-volt sawtooth to the X axis of the oscillograph and to the Type N Unit through the center connector of a miniature phone plug inserted in the EXT. TIME SWEEP jack. The outer conductor of the plug should be left floating. (Make the ground connection on a main-oscilloscope ground-post.) It is important that the sawtooth does not exceed +50 volts and that it does not go negative. If it exceeds +50 volts, the resistors in the NANOSEC/CM switch will be over-dissipated; if it goes negative, it will cause the Comparator Blocking Oscillator to free run and give an erroneous indication. The sawtooth should have a rate-of-change which is slow enough to allow the recorder's X and Y axes to stay within their normal error range.

The Y axis signal may be obtained either from the deflection plates of the oscilloscope crt or from the VERT. SIG. OUT connector on the oscilloscope front panel. In either case, the signal consists of approximately 2-microsecond-wide pulses spaced at the repetition period of the input signal (or 100 kc, if the input signal frequency is higher than 100 kc). Since most recorders are not able to respond to such signals, a special circuit will be required to detect the envelope of the pulses. If the signal has a high constant repetition rate, a simple low-pass filter may suffice if the signals are taken from the crt deflection plates.

APPLICATIONS

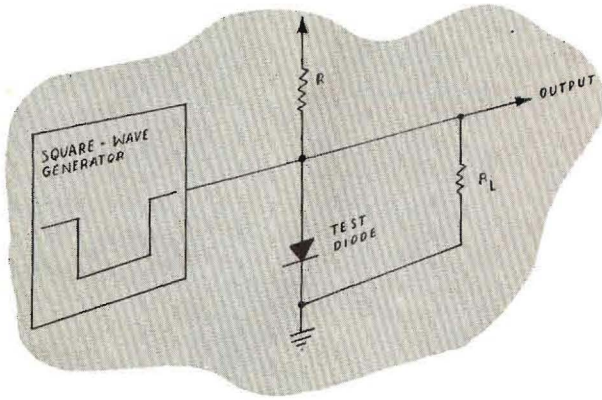

Representative Test Systems

Six representative test systems involving the Type N Sampling Plug-In Unit are described and illustrated in this section of the manual. These systems may be used as a basis for the development of more specialized systems as required by specific applications. This section will also show methods which may be used for impedance matching between the device under test and the 50-ohm Type N Unit.

The first three test systems shown are applicable where the device under test does not require external triggering. The last three systems apply where the device under test does require external triggering. In any of the systems shown it may be necessary to use attenuators to limit the signal going into the N Unit to a usable level. For simplicity of illustrations, these attenuators are not shown.

Time and voltage measurements on the signal itself are determined in the same manner as with any other plug-in unit, except that the vertical sensitivity of the N Unit is fixed at 10 millivolts per centimeter. Refer to the Operating In-

structions section of the manual for the oscilloscope you are using.

The N Unit by itself requires an external trigger. This trigger must arrive 45 to 235 nanoseconds ahead of the signal, as measured at the N Unit Inputs.

Fig. 3-1 illustrates a typical test setup where the device under test furnishes its own pre-pulse trigger. This trigger is between +0.5 and +2.0 volts in amplitude, at least one nanosecond in width, and between 45 and 235 nanoseconds in advance of the signal to be observed, as required by the N Unit. The trigger is connected to the TRIGGER INPUT connector on the N Unit, and the signal is connected to the SIGNAL INPUT connector on the N Unit.

Fig. 3-2 illustrates a typical test setup where the device under test has an associated trigger pulse of the proper amplitude and duration, but less than 45 nanoseconds in advance of the signal. The Type 113 Delay Cable has been inserted to delay the signal by 60 nanoseconds; thus, the associated trigger may occur as late as 15 nanoseconds after the signal to be observed. Since the Type 113 has

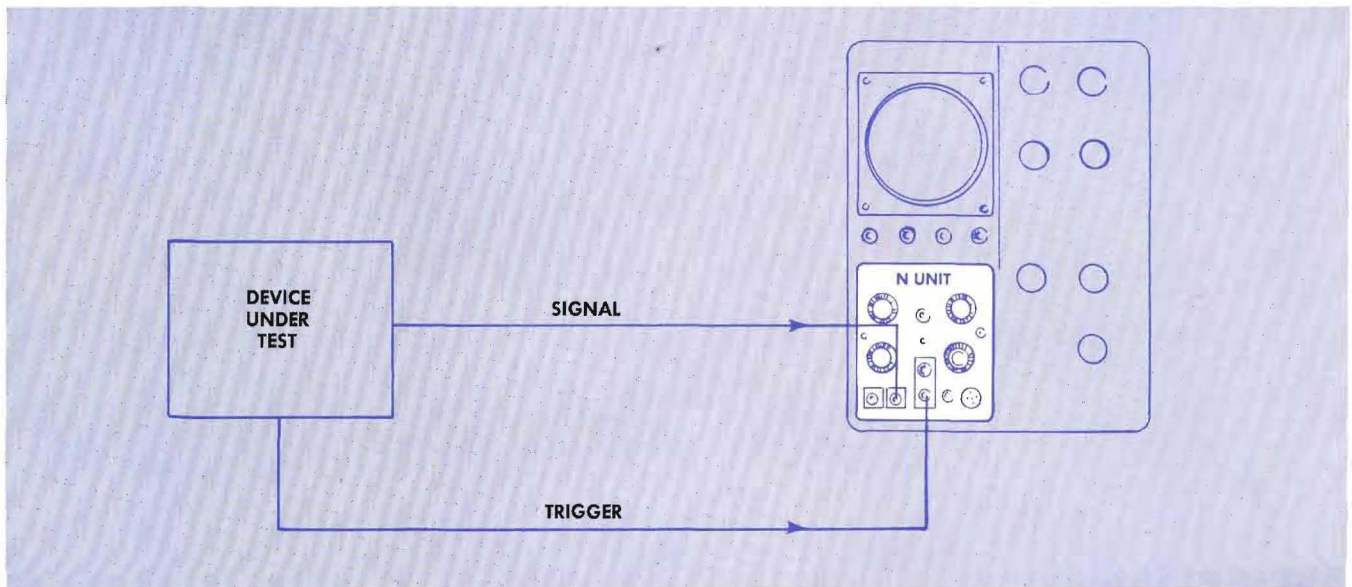

Fig. 3-1. Test setup where Device Under Test supplies its own trigger at least 45 nanoseconds in advance of the signal.

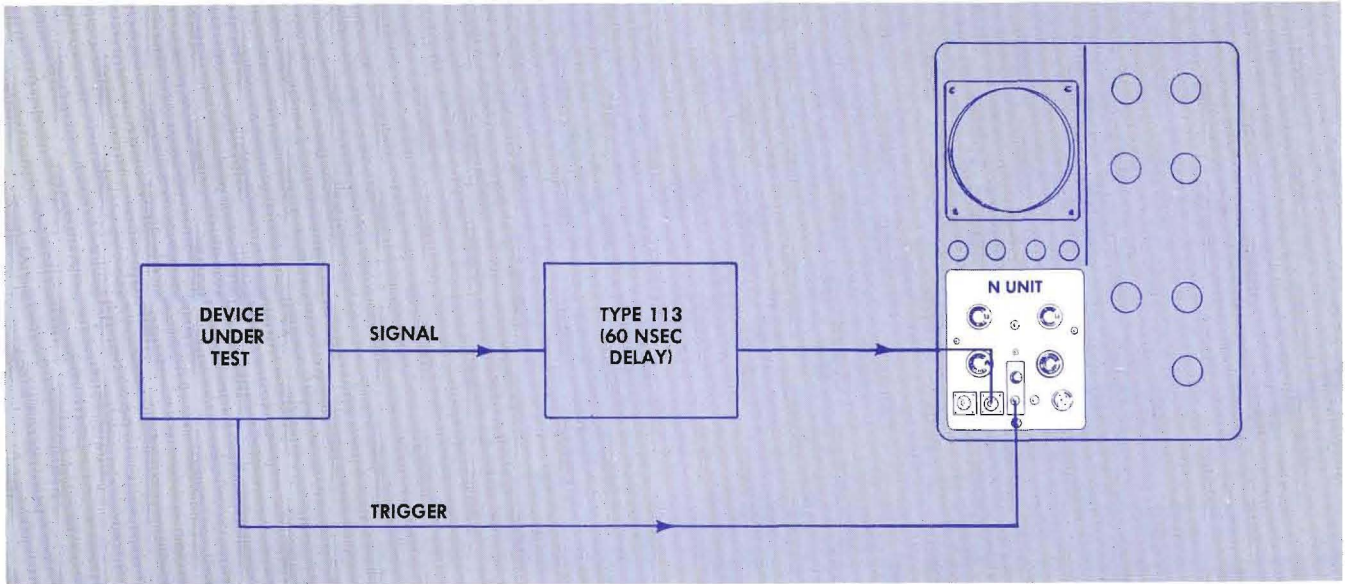

Fig. 3-2. Test setup where trigger does not precede signal by 45 nanoseconds.

a risetime of less than 0.1 nanosecond, it will not significantly alter the shape of any pulse which has a slower risetime than that of the N Unit (0.6 nanosecond).

Fig. 3-3 illustrates a typical test setup where the device under test does not have a trigger which falls within the amplitude and duration requirements for triggering the N Unit. The signal is applied through the Trigger Takeoff System of the Type 110 which picks off a portion of the signal to trigger the Trigger Regenerator. The regenerated trigger is then applied directly to the REGENERATED TRIGGER INPUT connector on the N Unit. The delay through the

Trigger Takeoff and Trigger Regenerator of the Type 110 is about 20 nanoseconds. Thus, the regenerated trigger from the Type 110 arrives at the N Unit 40 nanoseconds ahead of the signal as required for a regenerated trigger.

Fig. 3-4 illustrates a typical test setup where the device under test must be driven externally. This setup may also be used to measure the time delay inherent in the device under test.

To measure the delay of the signal by the device under test, proceed as follows: First, bypass the device under test and connect the output of the Type 113 directly to the

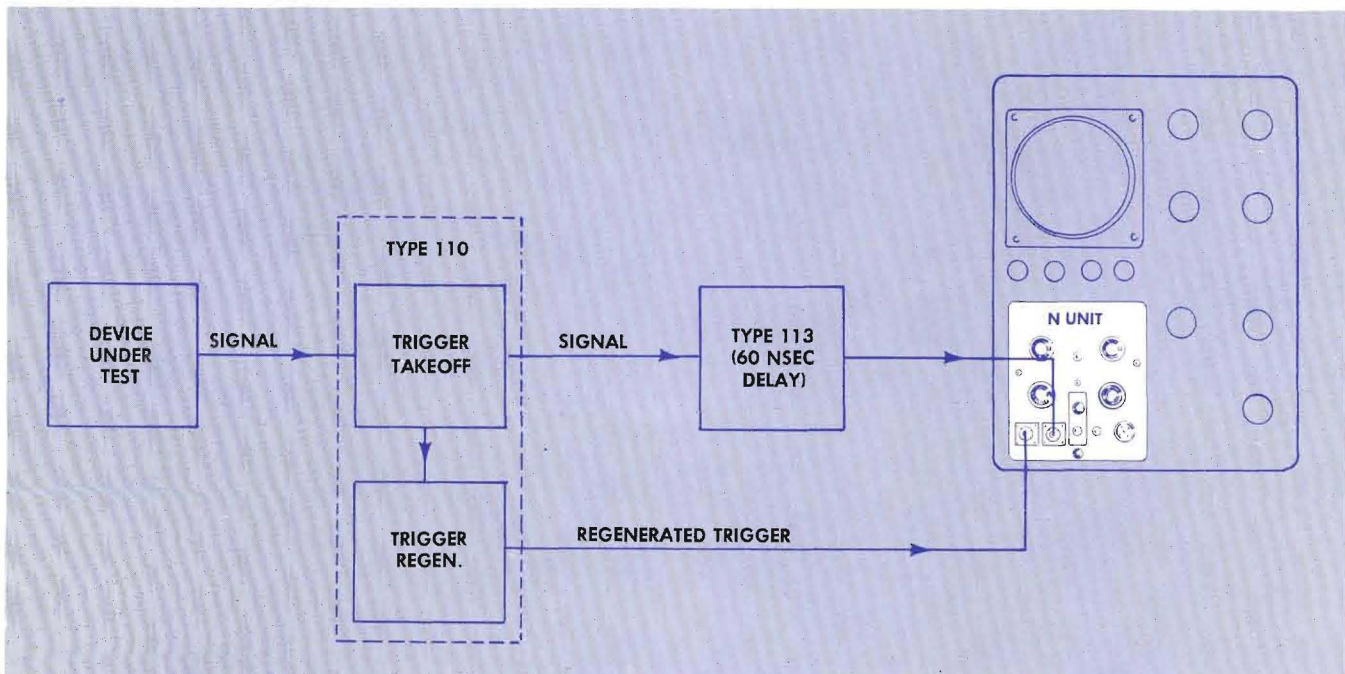

Fig. 3-3. Test setup where Device Under Test cannot supply required trigger.

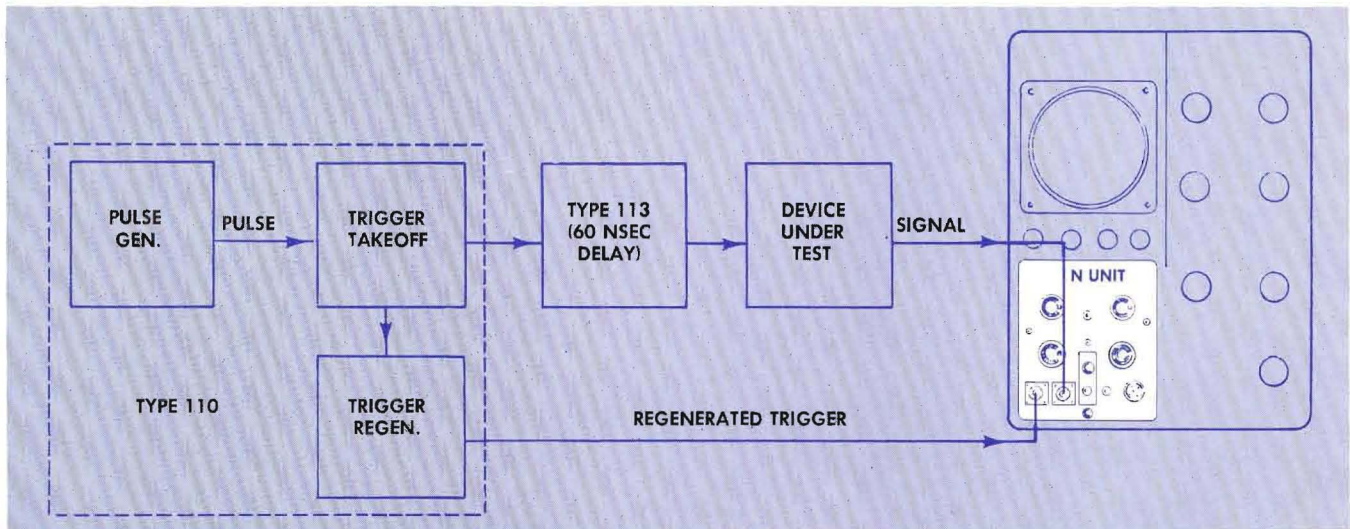

Fig. 3-4. Test setup where Device Under Test must be pulsed, and measurement of time delay is required.

cable from the SIGNAL INPUT connector on the Type N. Note the position of the waveform on the screen. Then, connect the device under test into the setup as shown. Note the new position of the waveform on the screen. Multiply the number of centimeters of shift by the setting of the NANO-SEC/CM switch. This is the delay of the device under test.

In some cases it may be desirable to reverse the order of the Type 113 and the device under test from that shown in Fig. 3-4. This is especially true where the device under test has a high output impedance and could be affected significantly by the arrival of possible spurious signals from the Type N due to the interrogating pulses in the Vertical Channel. Placing the Type 113 between the device under test and the Type N would delay these spurious signals

sufficiently to prevent them from affecting the display on the oscilloscope.

Fig. 3-5 illustrates a typical test setup where the output of the device under test is much greater than the input, and where it is not necessary to measure the amount of delay.

The test setup illustrated in Fig. 3-6 is virtually the same as that shown in Fig. 3-4 except that the pulse output to the device under test is delayed internally within the Type 111 rather than by the Type 113. The amount of time jitter on the face of the oscilloscope is increased to about 100 picoseconds with this arrangement. Also, the Type 111 risetime is about twice that of the Type 110; hence, the fastest risetime which can be displayed using it is about 0.7 or 0.8

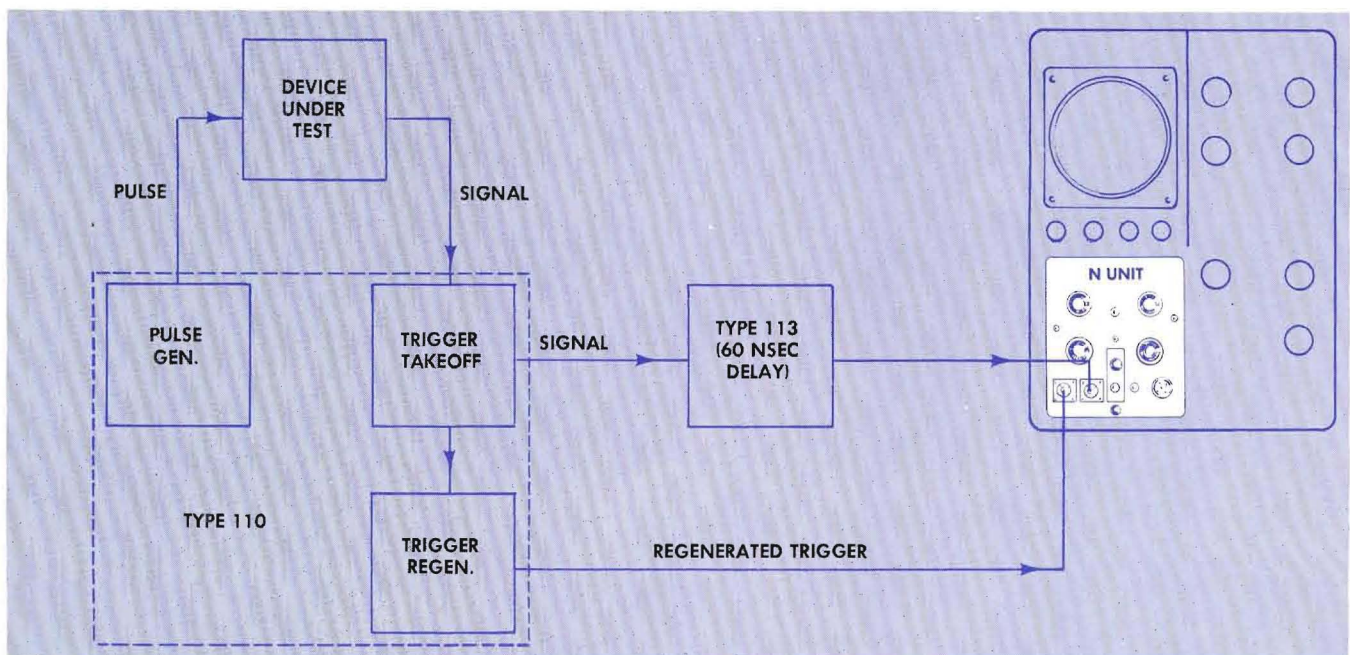

Fig. 3-5. Test setup where output of Device Under Test is much greater than input.

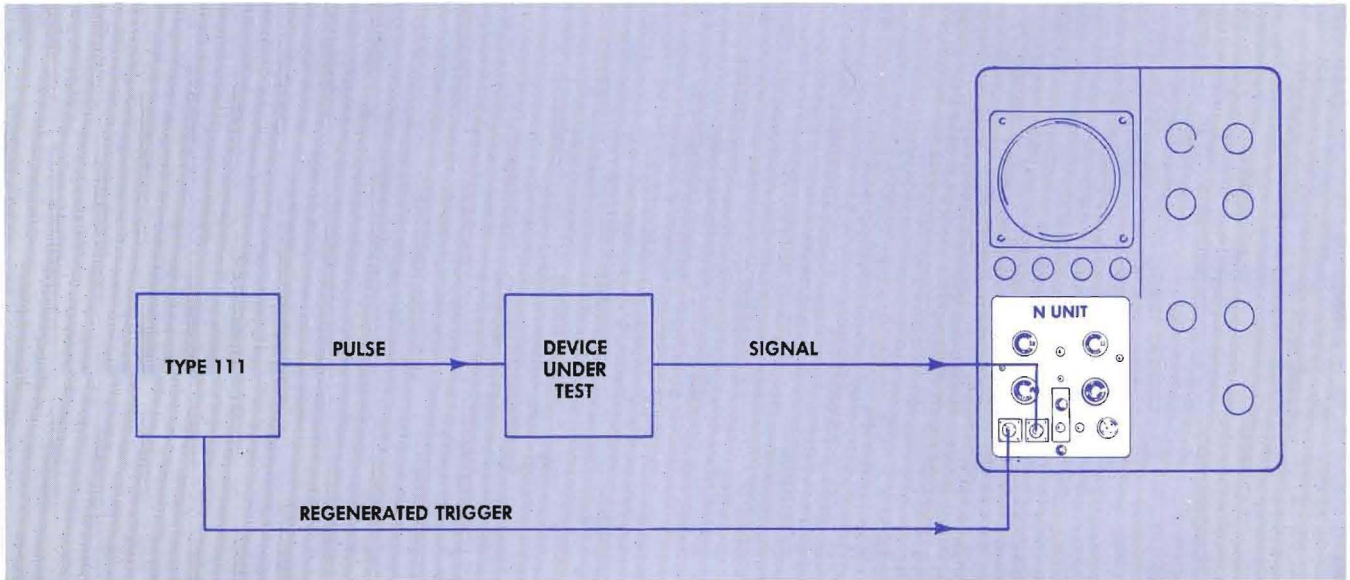

Fig. 3-6. Test setup using the Type 111 Pretrigger Pulse Generator.

nanosecond instead of 0.6 nanosecond as with the Type 110. However, since the repetition rate of the Type 111 goes to over 100 kc, this setup can make use of 500 samples per display to produce a virtually continuous display. (Using the 720-cps Pulse Generator in the Type 110, it is not possible to display more than about 1.5 sweeps per second at 500 samples per display.)

Connections to Signal Device

Figs. 3-7 and 3-8 illustrate two methods of "tapping off" the signal within the device under test for application to the Type N SIGNAL INPUT connector. The circuit changes required for Type N use are shown in color in each figure. Either method may be used at the output of the device as well as within the device itself.

The series method shown in Fig. 3-7 is basically as fol-

lows: Remove 50 ohms of any resistance to ground across which the signal is developed, and connect the 50-ohm pigtail in its place. In actual practice it may be possible, depending upon the value of R_L , merely to attach the pigtail between the lower end of R_L and ground without excessive change in loading. If R_L returns to a power supply instead of ground, insert a 50-ohm resistor between R_L and the power supply, and connect a blocking capacitor between the pigtail and the junction of R_L and the 50-ohm resistor.

In the shunt method shown in Fig. 3-8, R_S must be large enough to have negligible, or accountable, loading effect on the circuitry. In some cases, it may be desirable to increase R_L by an amount large enough to overcome this loading effect.

Experience will show that the physical positioning of R_S (Fig. 3-8), in relation to chassis ground, will affect the

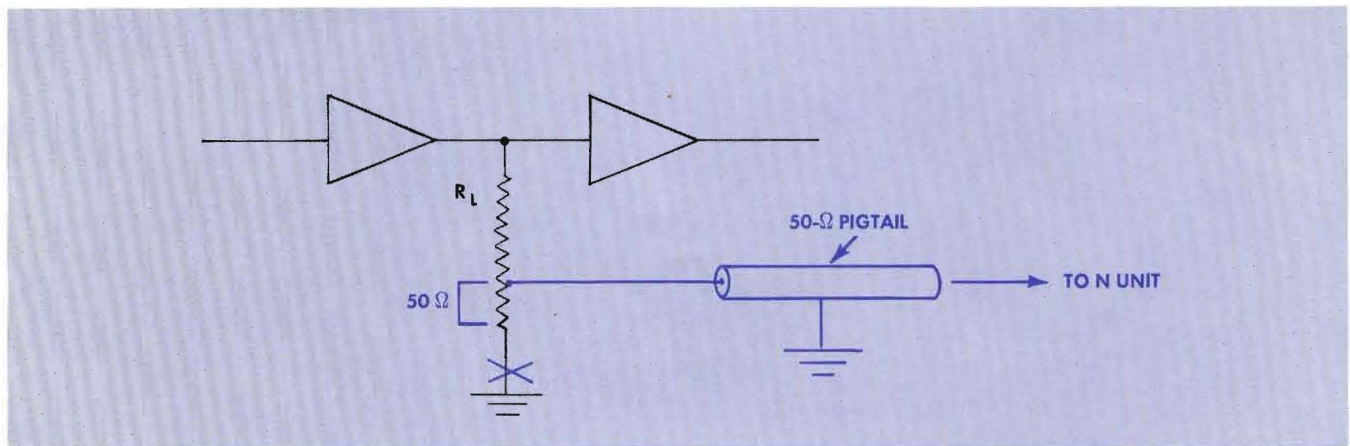

Fig. 3-7. Series method of tapping off signal for application to Type N Unit.

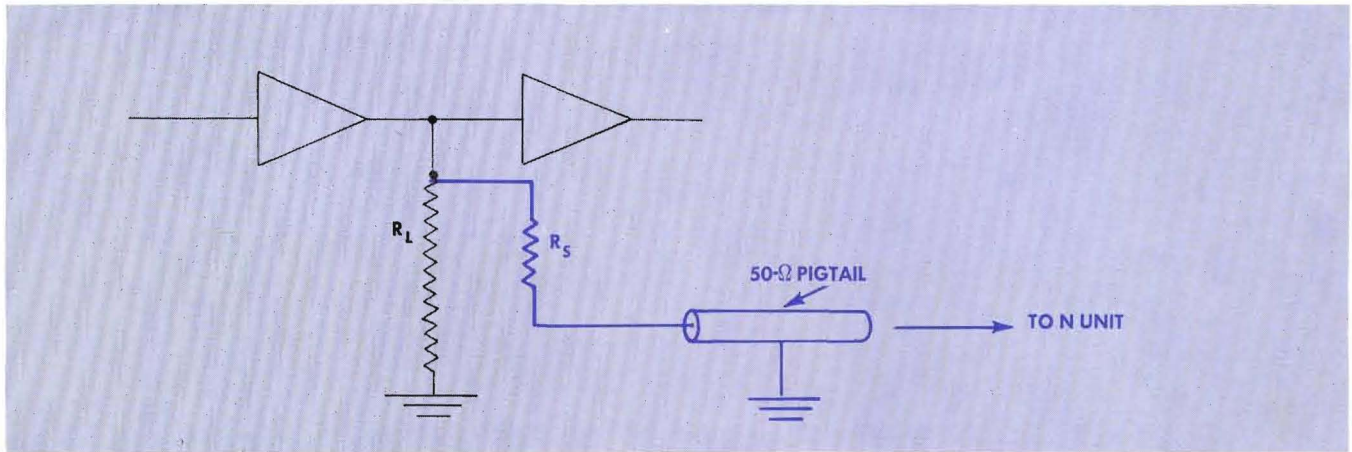

Fig. 3-8. Shunt method of tapping off signal for application to Type N Unit.

stray capacity and therefore the shape of the displayed signal. R_S should be positioned to provide the fastest rise, without overshoot, of a displayed output of the Type 110

or Type 111. In general, the larger the value of R_L , the farther the input end of R_S should be from the chassis compared to its output end (see Fig. 3-9).

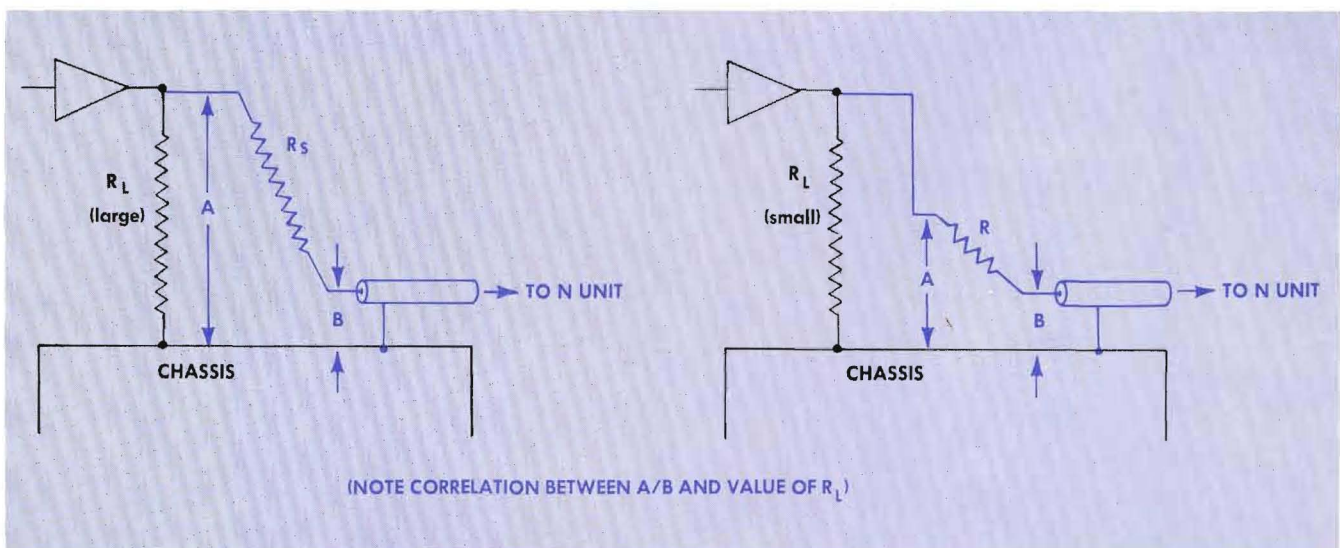
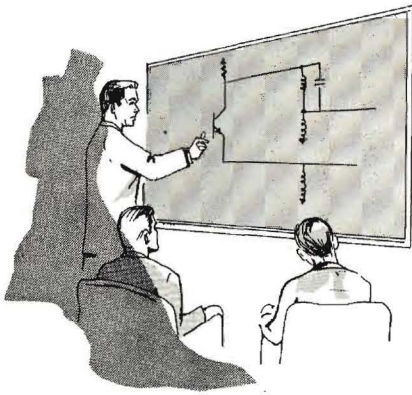

Fig. 3-9. Comparative physical positioning of R_S with large and small values of R_L .

NOTES

SECTION 4

CIRCUIT DESCRIPTION



GENERAL

The Pulse Generation Channel accepts trigger pulses either from the signal source under observation or from a regenerated trigger system and from them develops: (1) positive sampling pulses which are applied to the Vertical Channel memory circuit to sample the input waveform at particular instants of time; (2) negative pulses which are applied to the cathode to unblank the crt for presentation of each sample of the input waveform; (3) positive pulses which reset the Vertical Channel memory circuit after the sample has been displayed and prior to the next sample being made; (4) negative pulses which are applied to the Horizontal Channel to synchronize the staircase steps; and (5)

positive pulses which are applied to the Horizontal Channel to form the steps of the staircase sweep.

The Horizontal Channel develops the staircase sweep voltage which, in effect, "steps" the crt electron beam across the screen to permit the display of individual successive samples of the input waveform in the form of dots. This staircase sweep is externally connected from the TO EXT. HORIZ. connector on the plug-in unit to the External Horizontal Input connector on the oscilloscope. It is also fed back to the Pulse Generation Channel to cause the input waveform to be sampled at a slightly later instant of time in the cycle for each successive presentation on the screen.

The Vertical Channel algebraically adds the relatively large, short-time duration sampling pulse to the input signal.

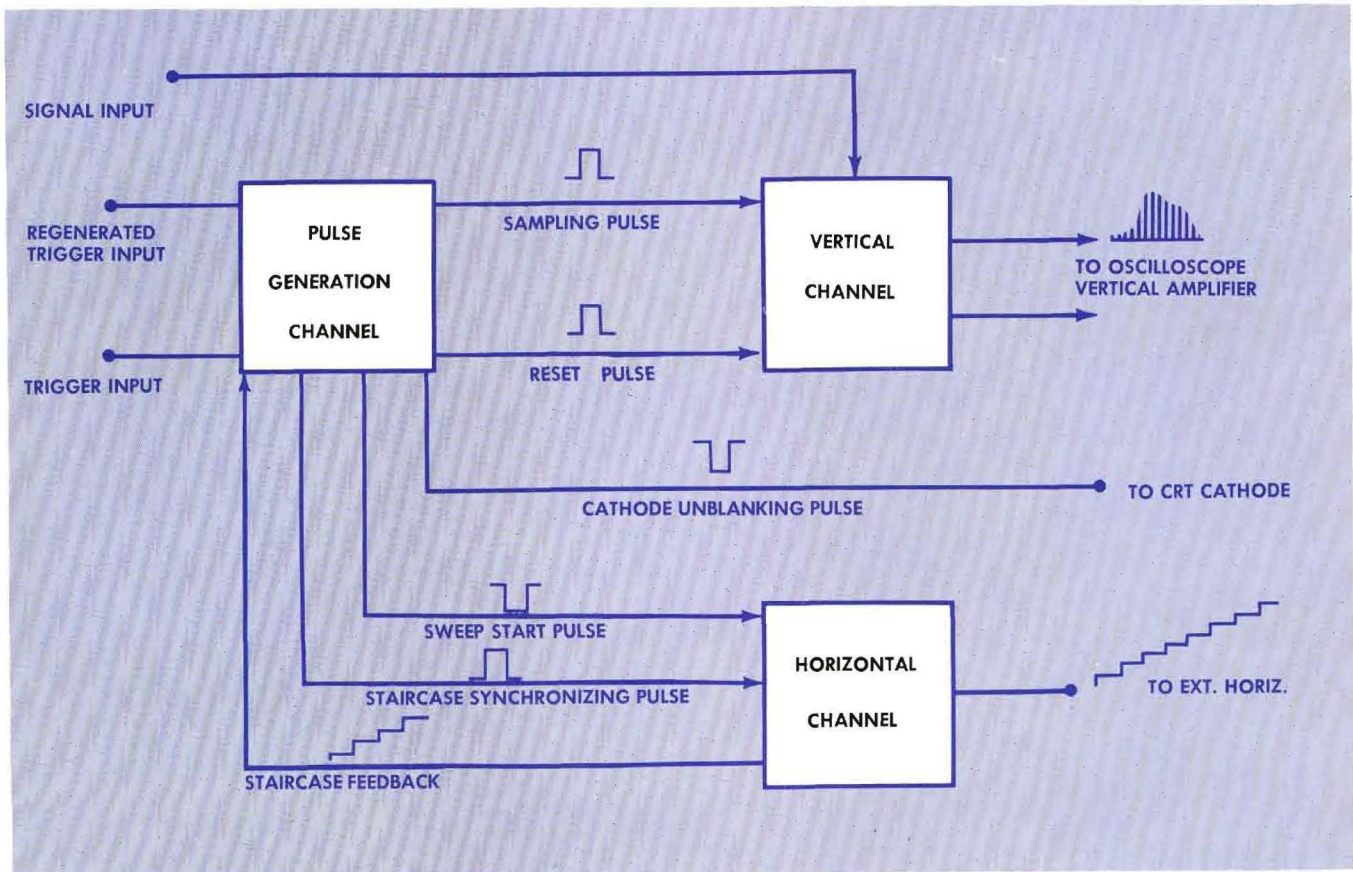

Fig. 4-1. Type N Sampling Plug-In block diagram

Circuit Description — Type N

The resulting waveform is applied to a back-biased diode, which drives a grounded-base transistor during the effective width of the sampling pulse to an output voltage proportional to the amplitude of the signal. The voltage on the transistor output capacitance constitutes a stretched sample of the signal at the time the sampling pulse occurs. This information is then displayed on the oscilloscope screen when the crt is unblanked.

PULSE GENERATION CHANNEL

For normal triggered operation of the Type N Unit, when a suitable trigger is available, the trigger pulse is applied to the TRIGGER INPUT connector on the front panel of the unit. Q5410 is biased slightly into cutoff by the setting of the TRIGGER SENSITIVITY control. When a positive trigger pulse appears at the collector of Q5410, T5410 induces a negative voltage at the base, and Q5410 conducts. Regenerative feedback through T5410 causes Q5410 to increase in conduction until the collector potential has gone so far in a positive direction that saturation of the transistor takes place. A further increase in current cannot occur since the charge on C5410 and the load (consisting of the "OR" gate and the base-emitter drive) determine the current initially. As the magnetizing current builds up in the transformer, the effective load discharging the capacitor increases and the voltage across the transistor increases, causing a small

change in the voltage across the magnetizing inductance of the transformer and across the load.

The magnetizing current builds up until the core saturates, which reduces base drive and causes the transistor to cut off. The charge accumulated on the base return capacitor C5406 during the "on" time places a positive voltage at the base of Q5410, keeping it cut off. The transformer's magnetizing inductance causes a back swing which is controlled by D5410. Circuit values have been chosen so that the output of the Trigger Regenerator is a positive gate approximately 10 volts in amplitude and 225 nanoseconds in width.

After the 225-nanosecond gate has ended, the charge on the base return capacitor will prevent further trigger pulses from taking Q5410 back into conduction until C5406 has discharged through R5406, R5407, and the -20 volt supply. After C5406 has discharged, the next positive trigger pulse will cause the Trigger Regenerator to conduct again. The MAX REP. RATE control, R5407, adjusts the discharge time of C5406 so that the maximum repetition rate of the Trigger Regenerator is approximately 100 kc, regardless of the frequency of the trigger pulses. This allows triggering on aperiodic signals below 100 kc, and on periodic signals above 100 kc to approximately 50 mc. By advancing the TRIGGER SENSITIVITY control in the clockwise (negative) direction, Q5410 can be forward biased, causing the Trigger Regenerator to free-run at approximately 100 kc.

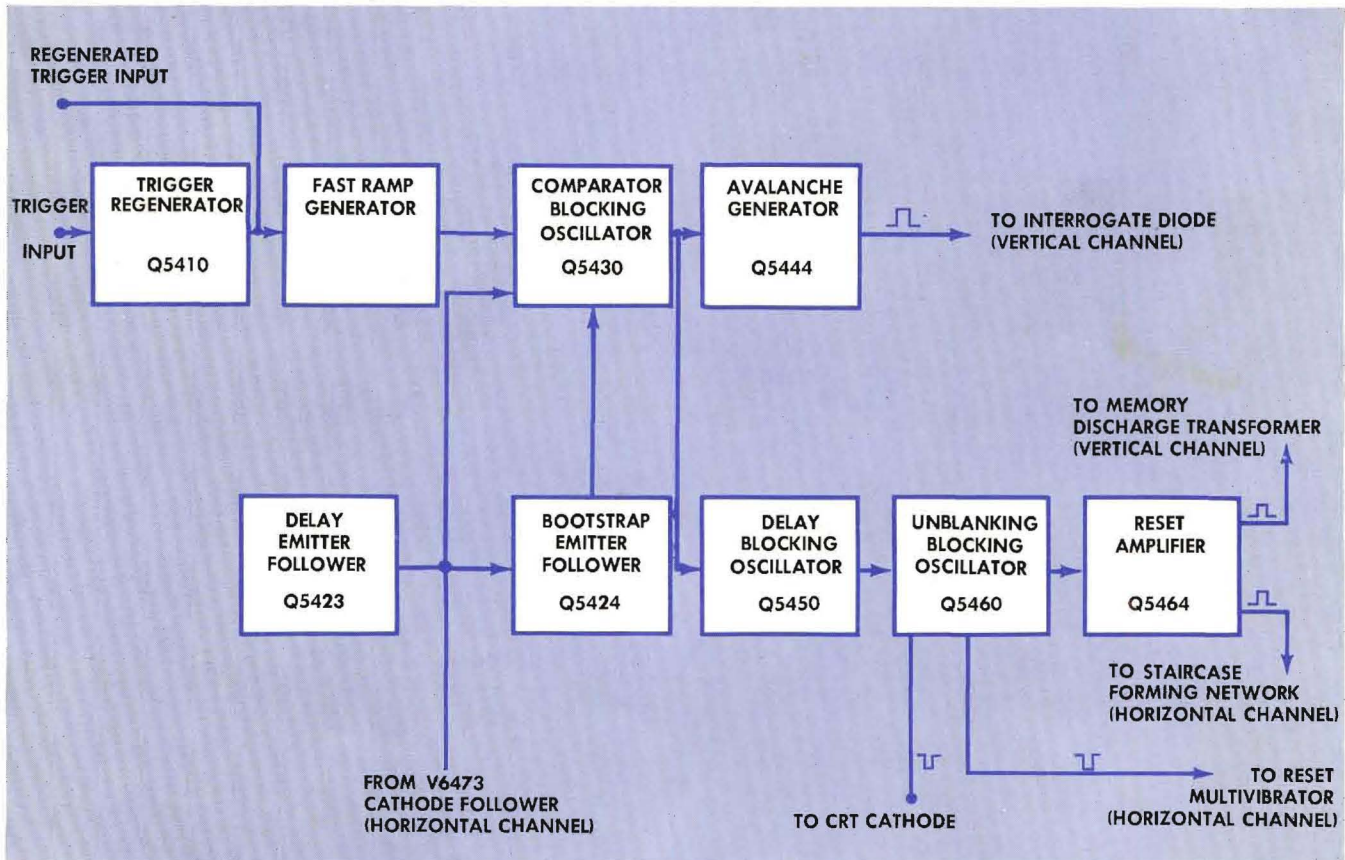

Fig. 4-2. Pulse Generation Channel block diagram.

When a signal source is used which does not have an associated trigger pulse suitable for driving the Trigger Regenerator of the Type N Unit, then it is necessary to use a separate trigger regeneration system, such as the Tektronix Type 110 Pulse Generator and Trigger Takeoff System of the Type 111 Pretrigger Pulse Generator. The externally regenerated trigger pulses must meet the same requirements as the output of the internal Trigger Regenerator; that is, they must be approximately +10 volts in amplitude, 225 nanoseconds in width, and not more than 100 kc in frequency. The input from such an external trigger regenerator is applied through the REGENERATED TRIGGER INPUT connector, D5413 and R5413 to the cathode of D5416, bypassing the Trigger Regenerator. When the externally regenerated trigger is used, the TRIGGER SENSITIVITY control is set to its extreme counterclockwise (positive) position to hold Q5410 in cutoff.

The 225-nanosecond gate from the Trigger Regenerator, or the externally regenerated trigger, is applied to the cathode of D5416 and gates the Fast Ramp Generator. The Fast Ramp Generator operates as follows:

During quiescent operation a current of approximately 10 ma flows from ground up through R5416 and R5417 in parallel, D5416, R5433, R5432 and R5431 to the +225-volt supply. The drop across R5416 and R5417 and D5416 places the emitter of Q5430 at approximately 1.0 volt above ground, and Q5430 is cut off. C5434 and C5435 are charged to 1.0 volt; there is no current through R5434 and R5435, and, therefore, no voltage drop across them.

When the positive gate is applied to the cathode of D5416, D5416 cuts off and allows the voltage at the emitter of Q5430 to move toward +225 volts. Almost instantaneously, the voltage steps about 0.15 volt due to the voltage divider action of R5434 and R5435, and R5432 between the 1.0 volt on the upper plates of C5434 and C5435 and the +225 supply. Also C5434 and C5435 start to charge exponentially toward +225. Since the gate is present for a maximum of only 225 nanoseconds and the RC time constant of the charging path is about 23 microseconds, only a very small portion of the charging curve will actually be used and the ramp voltage produced will be extremely linear. The result is a 0.15-volt step at the emitter of Q5430 followed by a linear ramp voltage which rises to a maximum amplitude of about two volts. The purpose of the 0.15-volt step is to overcome the safe hold-off bias on Q5430 without having to waste ramp time to do so.

Some time after the start of the ramp, depending upon the voltage at the base of Q5430, Q5430 will come into conduction. The voltage at the base of Q5430 is controlled by the dc level set by the DELAY control and the level of the staircase voltage fed back from the Staircase Generator in the Horizontal Channel. The voltage set by the DELAY control provides a basic constant delay between the start of the ramp and the firing of Q5430. The fed-back staircase voltage provides a further delay which becomes successively greater with each step of a sweep.

The amount of additional delay in the firing of Q5430 provided by each step of the staircase sweep depends upon the setting of the NANOSEC/CM switch. This in turn governs the relative time interval between interrogating pulses at the Vertical Channel input. Since, at a given setting of the SAMPLES/DISPLAY switch, the horizontal sweep always moves the same distance across the screen with each step,

varying the relative time interval between interrogating pulses changes the effective time per centimeter of the display; the greater the time interval between interrogating pulses, the greater the apparent time interval displayed per centimeter.

Insertion of a miniature phone plug in the EXT. TIME SWEEP connector breaks SW5420. When this happens, an external voltage applied through the inner conductor of the phone plug, rather than the staircase voltage from the Horizontal Channel, will determine the change in delay between the arrival of triggering signals and the occurrence of corresponding output pulses from Q5430. The relative change in delay produced by a given change in the external voltage will be the same as that produced by the same change in the staircase voltage when the switch is closed. (Note that a falling voltage at this point will cause the output pulses to occur relatively earlier with respect to their corresponding triggering signals.)

When the "master-slave" patch cord (Fig. 2-8) is used with two Type N Units for dual-trace operation, the circuit opened by insertion of the phone plug is immediately closed again in one unit by the connection between the outer and inner conductors of the "master" end of the cable. Then the signal from this unit is applied to the NANOSEC/CM switch in the other unit, while the staircase output of the second unit is left floating at this point.

As Q5430 starts to conduct, a sharp positive pulse is formed at the collector due to the blocking oscillator action. The emitter current of Q5430 discharges C5434 and C5435 very rapidly back toward ground. D5434 prevents the emitter of Q5430 from going negative by more than a small amount.

The Bootstrap Emitter Follower, Q5424, maintains a constant potential difference between the base and the collector of Q5430 regardless of the dc level at the base. This insures that the time delay between the overcoming of cutoff bias of Q5430 and the appearance of a pulse at its collector remains uniform throughout the sweep.

The sharp positive output pulse from Q5430 is coupled through C5441 to the collector of the Avalanche Transistor, Q5444, and through R5440 and C5440 to the emitter of the Delay Blocking Oscillator, Q5450. The base-to-collector junction of Q5444 is reverse-biased just short of breakdown so that when the positive spike from Q5430 is applied to the collector, Q5444 conducts heavily, producing a positive output pulse at the emitter.

The AVALANCHE SET control, R5442, and the AVALANCHE SENSITIVITY control, R5447, are used in conjunction with one another to select an optimum balance between pulse amplitude, stability, and delay time of the stage.

The purpose of the Delay Blocking Oscillator, Q5450, is to provide approximately one microsecond of delay in generating the unblanking pulse. This allows time for the sampling pulse to get through the Vertical Channel and be stored in the memory circuit before the crt is unblanked to display it on the screen. The positive pulse from Q5430 triggers the Delay Blanking Oscillator causing a positive pulse to appear at the collector of Q5450. The leading edge of the output pulse from Q5450 produces a negative going (from -20 volts) voltage at the junction of R5455 and R5456. This negative-going voltage charges C5455 through D5455. When the trailing edge of the pulse at the Q5450 collector oc-

Circuit Description — Type N

curs, a positive-going voltage appears at the junction of R5455 and R5456 which tends to charge C5455 in the opposite direction. D5455 is cut off and D5456 conducts, causing the positive rise to be coupled to collector of Q5460. The effect of the action of D5455 and D5456 is to delay the triggering of Q5460 by the width of the output pulse of Q5450. When Q5460 conducts, a positive-going pulse is obtained at the collector. The negative pulse induced at the other end of T5460 is applied to the TO CRT CATHODE connector on the front of the unit as the cathode unblanking pulse and to the Reset Multivibrator to synchronize the staircase sweep.

The leading edge of the positive pulse at the collector of Q5460 causes C5463 to charge through D5464. Then the negative-going trailing edge of the pulse causes C5463 to discharge through R5464. The result is a stretched negative pulse coupled to the base of Q5464 which is delayed by the width of the pulse appearing at the collector of Q5460. The output of Q5464 is a positive pulse which is applied to the Memory Discharge circuit, Q6432, in the Vertical Channel. The pulse causes the memory circuit to be discharged. The output of Q5464 is also applied to the staircase-forming network in the Horizontal Channel to cause the stairstep sweep to advance to its next voltage level.

VERTICAL CHANNEL

The positive pulse from the Avalanche Generator is dif-

ferentiated by C5479 and the R5479 network and superimposed on the incoming waveform at the input to the Vertical Channel. The reverse bias on the Interrogate Diode, D5480, is such that the incoming signal itself cannot cause the diode to conduct. The input signal is therefore effectively blocked by D5480. The sampling pulses do cause D5480 to conduct, however, and are coupled through the diode and C5480 to the emitter of Q5484. (The sampling pulses are of constant amplitude, on the order of one to two volts, whereas the maximum allowable signal amplitude is about 120 millivolts.) Since the sampling pulses are superimposed on the incoming waveform, the effective amplitude of each sampling pulse seen at the emitter of Q5484 is proportional to the amplitude of the signal at the time the pulse was applied. Since the time of occurrence of the sampling pulse (with respect to the signal) changes in proportion to the horizontal dot position, the envelope of a large number of successive pulses is a reproduction of the incoming signal.

Q5484 operates as a Class A amplifier with a long recovery time in the collector circuit and stretches the sampling pulse to 100 to 300 nanoseconds in width. The stretched pulse reduces the bandwidth and risetime requirements of the amplifiers that follow. Emitter Follower Q5493 acts as an impedance-matching device between the high output impedance of Q5484 and the low input impedance of Q5494.

Q5494 inverts the signal, amplifies it by a factor of ten, and applies it to a stretching network composed of C6400,

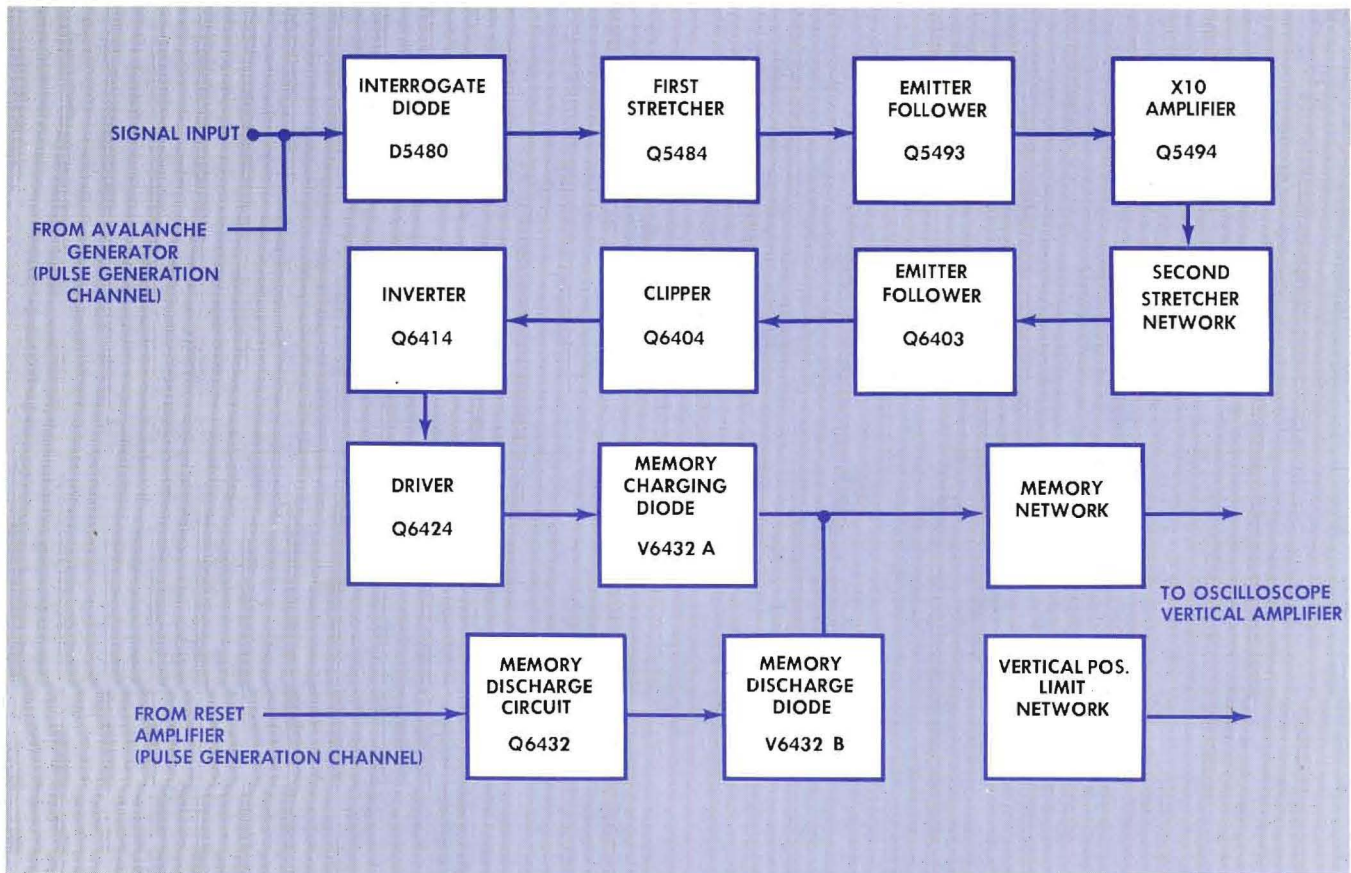

Fig. 4-3. Vertical Channel block diagram.

D6400, D6401 and R6401. The leading edge of the negative pulse biases D6401 for forward conduction which charges C6401. C6401 then discharges through R6401, yielding approximately a three-microsecond time constant. This further stretches the sampling pulse which is then applied to the Emitter Follower, Q6403. The output of Q6403, then, is a series of pedestals about two or three volts in amplitude, with the amplitude modulated by the incoming signal.

The following stage, Q6404, is biased for clipper action to conduct during the few hundred millivolts of modulation at the tips of the pedestals. The portion of the signal which extends into the conduction range of Q6404 is inverted and amplified by a factor of three or four.

The Inverter, Q6414, is biased well into its conduction range since the positive signal from the clipper will drive it toward cutoff. The Output Driver, Q6424, is biased just above cutoff since the negative-going signal from the Inverter will cause it to conduct more heavily. The output swing of Q6424 can be as much as 12 volts.

The positive output at the collector of the Output Driver, Q6424, is applied to the plate of V6432A and causes this tube to conduct, charging C6435 and C6436. (V6432B is held off by a reverse bias of about 12 volts developed by the voltage divider action of R6433 and R6434). The charge on C6436 is proportional to the amplitude of the positive pulse of Q6424 and is applied to the vertical deflection system of the oscilloscope. Due to the long discharge time constant, C6436 retains almost all of its charge until after the

crt has been unblanked by the crt unblanking pulse from T5460 in the Pulse Generation Channel. After the crt has been unblanked and the information stored in C6436 has been displayed on the screen, the positive reset pulse is applied to the base of Q6432 from Q5464 in the Pulse Generation Channel. This produces a negative pulse at the cathode of V6432B which causes V6432B, V6432A, and D6430 to conduct and discharge C6435 and C6436. They are then ready for the next signal pulse to be applied through the Vertical Channel.

HORIZONTAL CHANNEL

V6445A and V6445B form the Reset Multivibrator. Under quiescent (reset) conditions V6445A is conducting and V6445B is cut off. A negative pulse applied at the grid of V6445A from T5460 in the Pulse Generator Channel cuts off that half of the tube. A portion of the resulting positive swing in the plate voltage is applied to the grid of V6445B causing that half of the tube to conduct. (The conduction of V6445B raises the common cathode potential of V6445A and V6445B. This holds V6445A cut off until a sufficiently positive voltage is applied to its grid from the Hold-Off Circuit to cause it to conduct again.) The negative swing in voltage at the plate of V6445B cuts off the Disconnect Diodes, V6452A and V6452B

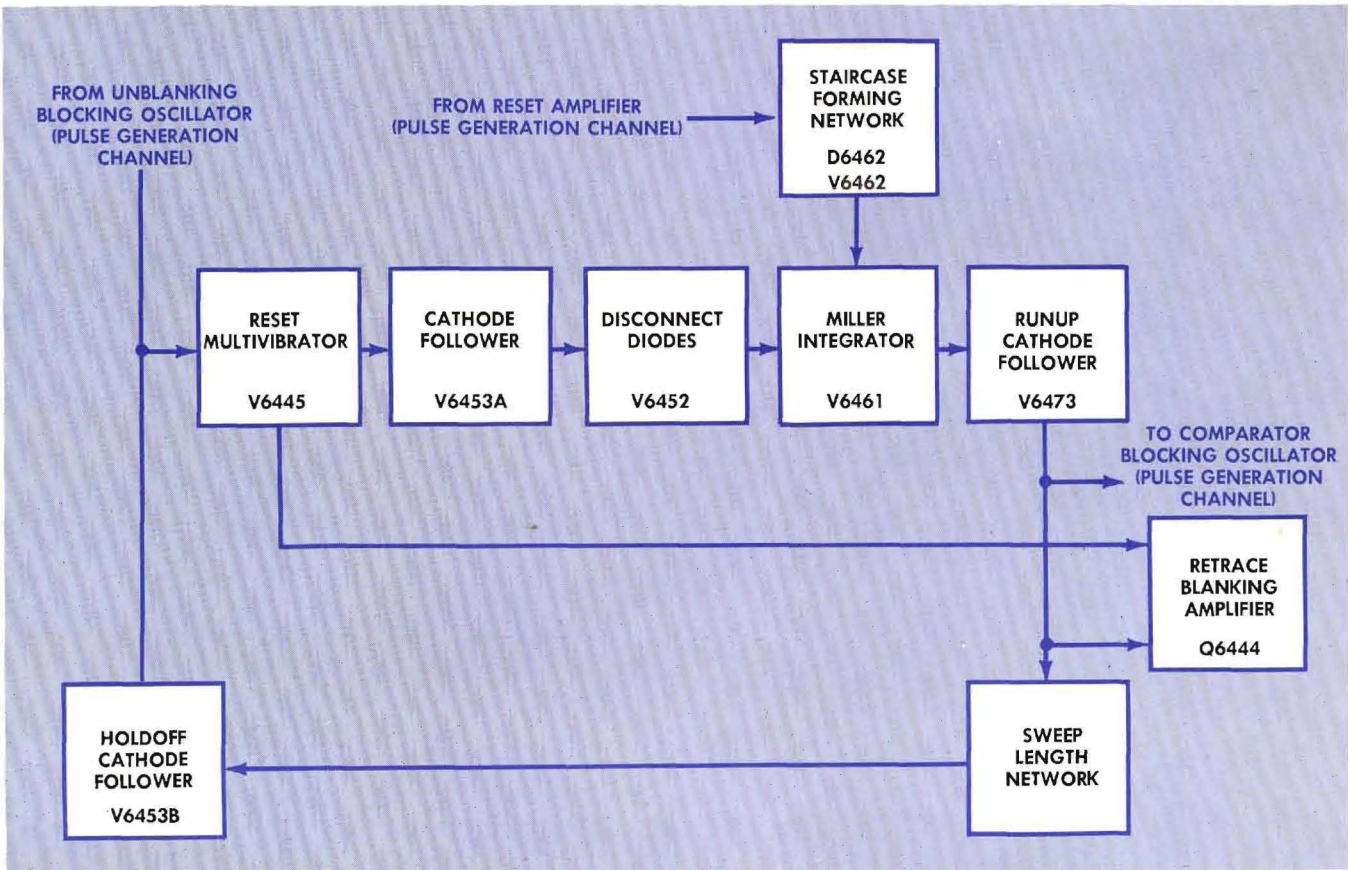

Fig. 4-4. Horizontal Channel block diagram.

Circuit Description — Type N

With its grid disconnected, V6461 is now ready to start forming the staircase horizontal sweep. The leading edge of the positive staircase-forming pulse from Q5464 in the Pulse Generation Channel causes one section of C6462 (depending upon the position of the SAMPLES/DISPLAY switch) to charge up through D6462. The negative-going trailing edge of the pulse then causes this charge to be transferred through V6462 to C6460. The result is a small negative step at the grid of V6461 which causes a positive step at the plate. Further positive staircase-forming pulses occurring at C6462 cause further small negative steps at the grid of V6461 and further positive steps at the plate of V6461. This action, then, forms a staircase sweep during which the sweep on the screen steps to the right as V6462 conducts and remains stationary while V6462 is cut off. It is during these periods while the sweep is stationary that the crt is unblanked and the information in the Vertical Channel is displayed on the screen.

The staircase sweep voltage is applied through the Cathode Follower, V6473, diodes D6472 and D6473, and the TO EXT. HORIZ. connector to the horizontal amplifier of the oscilloscope. The staircase voltage from the cathode of V6473 is fed back to the upper plate of C6460 to maintain the proper potential across the capacitor to maintain a constant amplitude of steps as the sweep progresses across the screen. From the cathode of V6473, the staircase voltage is also coupled back to the base of Q5430 in the Pulse Generation Channel to provide for a later firing of this transistor (in relation to the time of the triggering pulses) at each step of the sweep.

The voltage at the cathode of V6473 varies from approximately zero to +50 volts from one end of the sweep to the other. The Zener diode, D6472, maintains a 25-volt drop across itself so that the sweep seen at the TO EXT. HORIZ. connector progresses from approximately -25 volts to +25 volts in relation to ground. As the sweep voltage reaches +25 volts, V6453B conducts heavily enough to bring its cathode, and hence the grid of V6445A, sufficiently positive to cause V6445A to conduct. As V6445A conducts, its plate voltage drops. This voltage drop is coupled to the grid of V6445B, and V6445B cuts off. The plate voltage of V6445B rises, allowing the Disconnect Diode V6452B to conduct, causing the cathode follower V6473 to cut off. Then C6460 discharges until V6452A and V6473 come into conduction; this completes a dc feedback loop, setting the sweep starting potential.

The setting of the SAMPLES/DISPLAY switch determines the size of the sweep steps, thereby setting the number of steps required to carry the sweep through its entire 50-volt range.

During the sweep time, the hold-off capacitor C6457 is charged positively due to the cathode-follower action of V6453B. As the sweep ends and the grid of V6453B drops negatively, C6457 discharges through the -150-volt supply and R6457. Since the grid of V6445A is tied to the cathode of V6453B, the relatively slow discharge of C6457 holds the grid of V6445A far enough positive to prohibit incoming trigger pulses from triggering the Reset Multivibrator again

until the rest of the circuit has had a chance to return to its quiescent condition. After C6457 has discharged sufficiently to allow the cathode of V6453B to return to its normal quiescent voltage, then the next incoming negative trigger at the grid of V6445A will again trip the Reset Multivibrator and start the next sweep. The total hold-off time is about 200 microseconds.

Another action results as V6445A comes back into conduction and V6445B cuts off at the end of the sweep. The common cathode connection of V6445A and V6445B drops negatively due to the decrease in current through R6446. This negative drop in voltage is coupled through C6476 to the base of Q6444. Q6444 inverts the signal and applies it to the TO EXT. HORIZ. connector. This causes the trace to be moved off to the right of the screen to prevent the random appearance of any spot on the screen due to cathode unblanking during retrace time. Then at the start of the next sweep the multivibrator cathode again goes positive, cutting off Q6444 and permitting the cathode potential of V6473 to again control the spot. At this time the sweep circuit is completely reset, and the beam is moved to the left side of the screen within about five microseconds, too quickly for a crt unblanking pulse to occur before it gets back.

POWER SUPPLY

The two power supply circuits are virtually identical except for polarity of output. Both are series regulated and use the oscilloscope +100-volt supply as a reference.

To examine the operation of the +20-volt supply regulation circuit, assume that the load on the supply increases such that more current is required. The initial effect is to drop the voltage level at the emitter of Q6484. The base of Q6484 is held at +20 volts by the voltage divider R6482-R6483 connected between the reference (+100 volts) and ground. With the emitter negative with respect to the base, Q6484 conducts less current. This reduces the drop across R6484 and results in a more negative voltage at the base of Q6483. Q6483 conducts more heavily, causing a larger drop across R6486. This places a more negative voltage at the base of Q6487. The internal impedance of Q6487 is thereby reduced, and more current flows through it to the load.

If the load decreases, such that less current is required, the effects throughout the supply are just the opposite. The result is that the internal impedance of Q6487 is increased and less current is supplied to the load.

In the -20-volt supply, the action is the same except that variations in the output are applied to the collector of Q6494, rather than the emitter. R6495 and C6495 are placed in the -20 volt supply to dampen out a tendency for that supply to ring at certain frequencies.

The PROBE POWER connector provides a front-panel source of +100 volts dc, 6.3 volts ac, and ground for operation of a cathode-follower probe.

MAINTENANCE

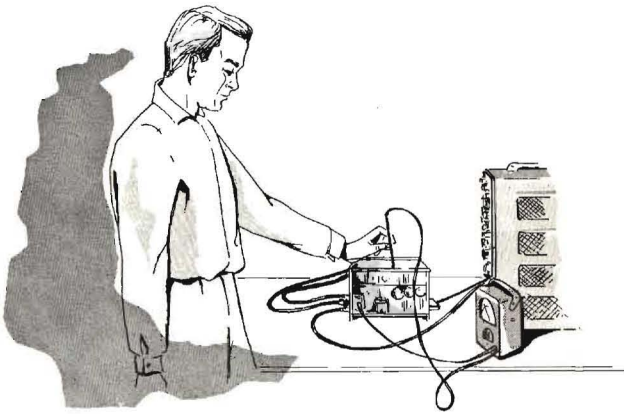

PREVENTIVE MAINTENANCE

Visual Inspection

You should visually inspect the Type N Sampling Plug-In Unit periodically for possible circuit defects. These defects may include such things as loose or broken connections, damaged binding posts, improperly seated tubes, scorched wires or resistors, or broken terminal pins. For most visual troubles the remedy is apparent; however, particular care must be taken when heat-damaged components are detected. Overheating of parts is often the result of other, less apparent, defects in the circuit. It is essential that you determine the cause of overheating before replacing heat-damaged parts in order to prevent further damage.

Recalibration

The Type N Sampling Plug-In Unit is a stable instrument and should provide many hours of trouble-free operation. However, to insure the reliability of measurements obtained with the Type N Unit, we suggest its calibration be checked after each 500 hours of operation (or every six months if it is used intermittently). A check of the calibration also provides a means for checking the operation of each circuit. Minor operational deficiencies that are not apparent in normal use are often detected during a calibration check. A complete step-by-step procedure for checking the calibration of the instrument is included in the Calibration Procedure of this manual.

REMOVAL AND REPLACEMENT OF PARTS

General Information

Procedures required for replacement of the parts in the Type N Sampling Plug-In Unit are obvious. Detailed instructions for their removal are therefore not required. Because of the nature of the instrument, replacement of certain parts will require that you calibrate portions of the instrument to insure proper operation. Refer to the Calibration Procedure section of this manual.

Tube Replacement

Care should be taken both in preventive and corrective maintenance that tubes are not replaced unless they are

actually causing a trouble. Many times during routine maintenance it will be necessary for you to remove tubes from their sockets. It is important that these tubes be returned to the same sockets unless they are actually defective. Unnecessary replacement or switching of tubes will many times necessitate recalibration of the instrument. If tubes do require replacement, it is recommended that they be replaced with previously checked high-quality tubes.

Soldering Precautions

In the production of Tektronix instruments a special silver-bearing solder is used to establish a bond to the ceramic terminal strips. This bond may be broken by repeated use of ordinary tin-lead solder, or by excessive heating of the terminal strip with a soldering iron. However, occasional use of ordinary solder will not break the bond if too much heat is not applied.

In those shops responsible for the maintenance of several Tektronix instruments it is advisable to have a stock of solder containing about 3% silver. This type of solder is used frequently in printed-circuit work and is generally available locally. It can also be purchased from Tektronix in one-pound rolls; order by part number 251-514.

Due to the wide-band requirements of the Type N Unit, many of the parts are soldered in place with very short leads. The proper technique for soldering and unsoldering short-lead components requires: (1) the use of needle nose pliers between the soldering point and the component to act as a heat shunt; (2) the use of a very hot iron for a short time; and (3) careful manipulation, because many of the small components have weak leads.

REPLACEMENT PARTS

Standard Parts

Replacement parts can be obtained from Tektronix at current net prices. However, since most of the components are standard parts they can usually be purchased locally. Before ordering or purchasing parts, be sure to consult the Parts List to determine the tolerances required. The Parts List gives the value, tolerance, rating and Tektronix part number for all components used in the instrument.

Tektronix-Manufactured Parts

Tektronix manufactures almost all of the mechanical parts, and some of the electronic components, used in your instru-

Maintenance — Type N

ment. When ordering mechanical parts, be sure to describe the part completely to prevent delays in filling your order.

The Tektronix-manufactured electronic components are so noted in the parts list. These parts and all mechanical parts must be ordered directly from Tektronix since they will normally be impossible to obtain from other sources. All parts may be obtained directly from the factory or from the local Tektronix field office.

Parts Ordering Information

Each component in this instrument has a six-digit Tektronix part number. This number, together with a description of the part, will be found in the Parts List. To expedite filling your order be sure to include the following information when ordering parts:

1. A description of the part.
2. The part number.
3. The instrument type and serial number.

For example, a certain diode should be ordered as follows: D6491, 100 p.i.v., 400 ma, part number 152-009 for Type N Sampling Plug-In Unit, Serial Number _____. When parts are ordered in this manner we are able to fill the order promptly and delays that might result from transposed digits in the part number are avoided.

NOTE

Always include the instrument TYPE and SERIAL NUMBER in any correspondence concerning this instrument.

Since the production of this instrument some of the components may have been superseded with newer, improved components. If we receive an order for a component that has been superseded by a newer one, the new one will be shipped in place of the original. All Tektronix field offices have knowledge of these changes, and your local Field Engineer may call you if a change in your purchase order is necessary.

Replacement information notes sometimes accompany the new components to aid in their installation.

TROUBLESHOOTING

General Information

This section of the manual contains information for troubleshooting the Type N Sampling Plug-In Unit. This information can be used, when trouble exists, to help in isolating the defective circuit stage.

Before attempting to troubleshoot the instrument, make sure that any apparent trouble is actually due to a malfunction within the plug-in, and not to improper control settings or to a circuit failure in the equipment under test.

Any defect that may be apparent in the crt display of an oscilloscope (or the absence of a display) may be due to a malfunction in either the plug-in or the oscilloscope itself. The faulty unit can readily be determined by inserting

another plug-in unit, known to be in operating condition, into the oscilloscope and checking the results. If the trouble is still apparent, it can be assumed that the original plug-in unit is not at fault, and the circuit failure lies somewhere within the oscilloscope. However, should the trouble appear to have been corrected, it is almost a certainty that the defect lies within the plug-in unit itself.

Some apparent troubles in the Type N Unit may be due to improper calibration of one or more of the circuits. Instructions for checking the calibration adjustments are included in the Calibration Procedure section of this manual. In the following troubleshooting procedures, it is assumed that the oscilloscope is operating correctly and is properly calibrated.

Schematic diagrams are contained in the Parts List and Schematic Diagrams booklet used in conjunction with this manual. In addition, a block diagram provides an overall picture of instrument operation. The reference designation of each electronic component in the instrument is shown in the circuit diagram.

The material which follows contains information for troubleshooting each circuit for trouble which may be caused by a defect in the circuit. The techniques described will assist in isolating a fault to a given stage or circuit. Once the faulty circuit is known, the particular component or components causing the trouble can be located by voltage and resistance measurements or by substitution.

Due to circuit configurations used in the Type N Sampling Plug-In Unit, it is possible for an incorrect power supply voltage to affect one circuit more than others. For this reason, power supply voltages (+20 volts and -20 volts) should be checked first whenever any type of trouble occurs within the instrument. Both the +20- and -20-volt supplies are referenced to the oscilloscope 100-volt supply, so it is well to verify that the oscilloscope 100-volt supply is operating properly before troubleshooting the Type N Unit power supplies.

Tube or transistor failure is the most prevalent cause of circuit failure. Before replacing a tube or transistor, however, make a complete visual inspection of the suspected circuit or channel to see that associated components have not been damaged. Shorted tubes will sometimes overload and damage plate-load and cathode resistors. A visual inspection may also reveal other types of component damage such as broken connections, terminal strips, and switch wafers. These improper circuit conditions could cause damage to a new transistor.

Troubleshooting Test Setup

The following test setup should be used when troubleshooting the Type N Unit. With the Type N Unit inserted in an oscilloscope, connect the horizontal amplifier cable from the TO EXT. HORIZ. connector on the plug-in to the external horizontal input connector on the oscilloscope, and the cathode unblanking cable from the TO CRT CATHODE connector on the plug-in to the crt cathode connectors on the back of the oscilloscope.

NOTE

If there is a CRT CATHODE SELECTOR switch on the oscilloscope, it should be placed in the EXTERNAL CRT CATHODE position before the cable is connected. Also the ground strap should be removed from the crt cathode connector.

Connect the 50-ohm termination cable shown in Fig. 6-2 to the SIGNAL INPUT connector on the Type N Unit. Set the TRIGGER SENSITIVITY control to the FREE RUN position. Turn the oscilloscope on and allow it to warm up for at least one minute before making any measurements.

For ease in troubleshooting, a plug-in extension may be used to allow the oscilloscope to be operated with the plug-in partially or completely out of its housing. (See Accessories Section.)

A Tektronix Type 540-Series Oscilloscope with a Type L Plug-In Unit was used in obtaining the waveforms shown in this section. It is suggested that this type of oscilloscope, or its equivalent, be used for troubleshooting the Type N Unit.

No Spot or Trace

A horizontal trace (made up of dots) should appear on the crt when the TRIGGER SENSITIVITY control is turned to the FREE RUN position and the VERTICAL POSITION and

HORIZONTAL POSITION controls are properly adjusted. If there is no display on the crt or if only a spot appears, the first step should be to check the output waveforms of the Pulse Generation Channels at the points shown in Fig. 5-1. The waveforms should appear similar to the samples shown.

If the trouble is found to be in the Pulse Generation Channel, checking of the waveform at the points shown in Fig. 5-2 should help to isolate the circuit in which the trouble exists. If a trouble appears to exist in the Trigger Regenerator, this can be verified by applying an externally regenerated trigger from some device such as the Tektronix Type 110 Pulse Generator and Trigger Takeoff System to the REGENERATED TRIGGER INPUT connector, and again checking the waveforms at the points shown in Fig. 5-1. It should be noted that a trouble in the Comparator circuit could be due to a malfunction of the Bootstrap Emitter Follower.

If all of the Pulse Generation Channel output waveforms appear normal, then the trouble is in either the Vertical

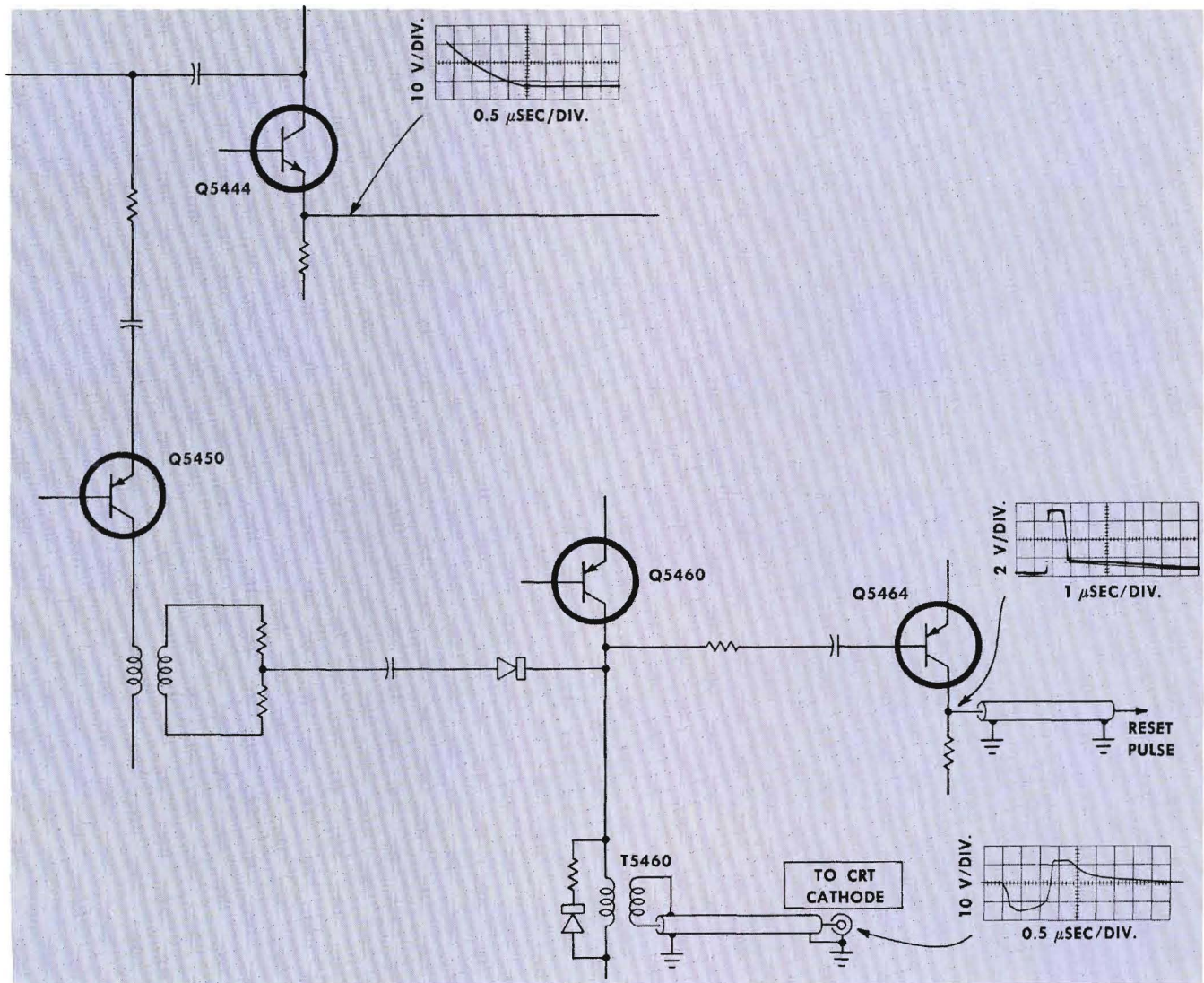

Fig. 5-1. Pulse Generator Channel output waveforms.

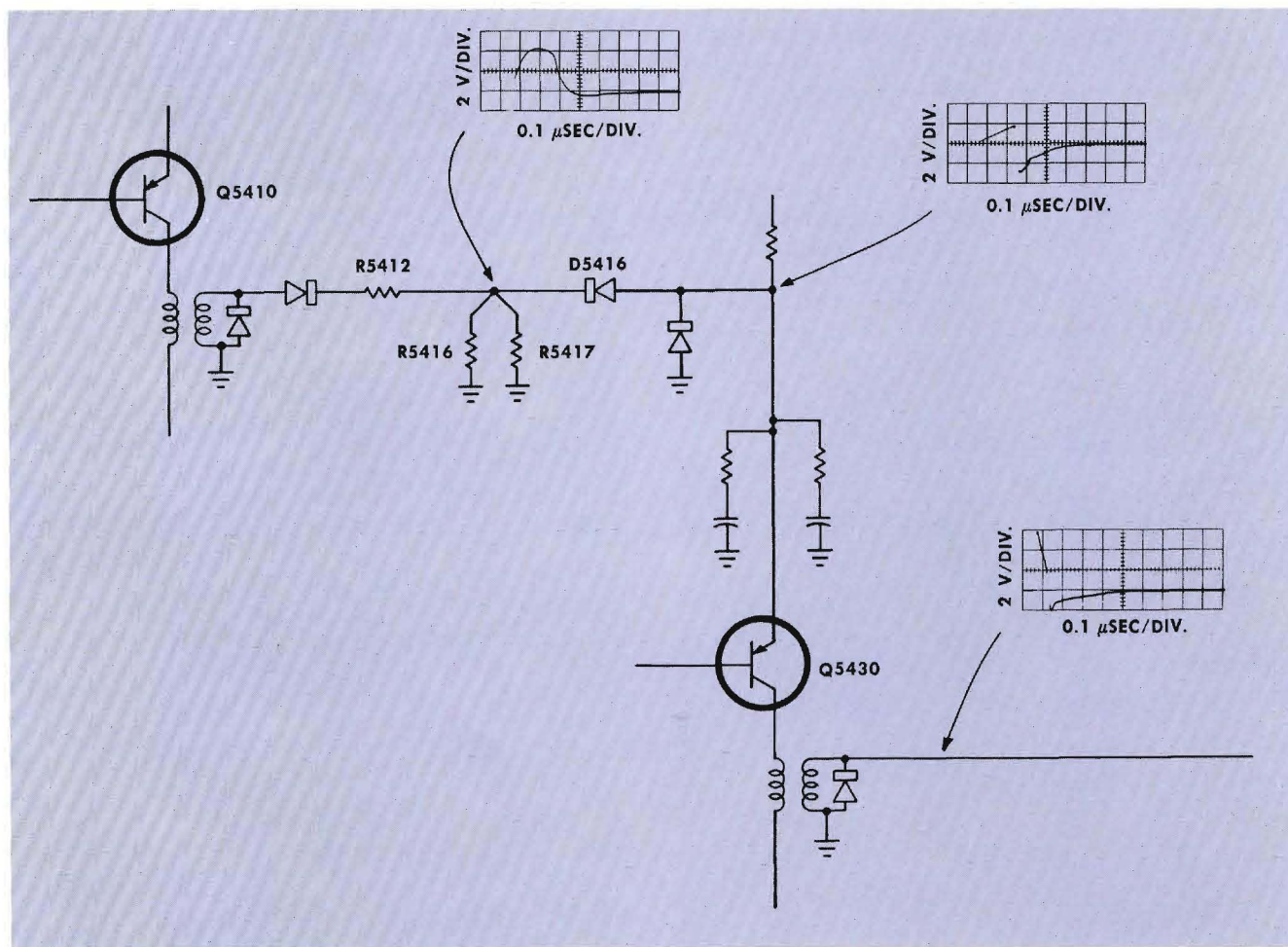

Fig. 5-2. Pulse Generator internal waveforms.

Channel or the Horizontal Channel. If there is a spot on the screen, then the trouble is in the Horizontal Channel. If there is no display on the screen, but a trace can be obtained by turning the INTENSITY control fully clockwise and adjusting the VERTICAL POS. LIMIT control, then the trouble is in the Vertical Channel. If a display cannot be obtained regardless of the settings of the INTENSITY and VERTICAL POS. LIMIT controls, then the trouble is probably in the dc portions of the Vertical Channel output circuitry. This can be checked quickly by measuring the voltages at pins 1 and 3 of the plug-in connector. The voltage at pin 1 should be approximately +67 volts; the voltage at pin 3 should vary from about +67 to +70 volts as the VERTICAL POS. LIMIT control is turned through its entire range.

Procedures for troubleshooting the Horizontal Channel and the rest of the Vertical Channel follow.

The first step in troubleshooting the Horizontal Channel (after visually checking for heater glow, loose leads, broken switches, etc.) should be a check of the waveforms at the inputs to the Reset Multivibrator (pin 2 of V6445) and to the Charging Diodes (cathode circuit of V6462). At both of these points there should be a series of sharp negative

pulses approximately 10 microseconds apart. If either of these inputs is missing, and all outputs of the Pulse Generation Channel are normal, the trouble exists in the coupling between the Pulse Generation Channel and the points tested.

If both of the input waveforms are present, the next step should be to measure the plate voltage of the Miller Integrator Tube, V6461. During normal operation the plate voltage of this tube is approximately 70 to 75 volts. Usually, when the Horizontal Channel is not operating properly, the plate voltage of V6461 is either about 50 volts or over 200 volts, depending upon whether or not the tube is conducting.

If the voltage at the plate of V6461 is approximately 50 volts, the tube is conducting. This means that its grid is being held near ground, probably by conduction of V6452B. Measure the voltage at the plate of V6452B (pin 2). If this voltage is negative with respect to ground by 10 volts or more, then V6452B is not conducting and the trouble is in the grid circuit of V6461, probably in V6462 or D6462. If the voltage at the plate of V6452B is near ground (± 2 volts), measure the voltage at the plate of V6445B. If it is at -10 volts or below, the trouble exists in the Reset Cathode Follower circuit. If the plate voltage of V6445B is

within about 2 volts of ground, measure the voltage at the the grid of V6445A. If it is in the vicinity of -90 volts or lower, then the trouble lies within the multivibrator. If the voltage at the grid of V6445A is -75 volts or higher (more positive), measure the voltage at the grid of V6453B. This voltage should be within a few volts of that measured at the grid of V6445A. If it is not, then the trouble is within the Hold-Off Circuit. If the voltage at the grid of V6453B is approximately the same as that measured at the grid of V6445A, then the trouble lies in the Runup Cathode Follower circuit or the Sweep Length divider network.

If the plate of V6461 is at $+200$ volts or more, the tube is cut off. If this is the case, momentarily ground the grid of the tube. If the tube is good, the plate voltage should drop to a lower value, probably between 0 and $+50$ volts. If V6461 is found to be good, measure the voltage at the plate of V6452B. It should be about -15 volts. If it is not, then the trouble is probably an open V6452B. If the plate voltage of V6452B is about -15 volts, measure the voltage at the plate of V6445B. If it is at about ground level, then the trouble exists in the Reset Cathode Follower circuit. If the plate voltage of V6445B is about -12 volts, measure the voltage at the grid of V6445A. If it is in the vicinity of -50 volts or higher, then the trouble is within the multivibrator. If the voltage at the grid of V6445A is -75 volts or lower, then the multivibrator is apparently not at fault and you should measure the voltage at the grid of

V6453B. It should be within a few volts of the voltage measured at the grid of V6445A. If it is not, then the trouble exists in the Hold-Off Circuit. If the voltage at the grid of V6453B is within a few volts of that measured at the grid of V6445A, then the trouble exists in the Runup Cathode Follower circuit or the Sweep Length divider network.

Troubleshooting the Vertical Channel may be accomplished by tracing the sampling pulse through each stage with a test oscilloscope. Test points are shown in Fig. 5-3. Approximate waveforms which should be present at each of these test points are shown in Fig. 5-4.

Rotation of the VERTICAL POSITION control varies the amplitude of the sampling pulse in the Vertical Channel. In order to obtain the waveforms of the amplitude shown, set the VERTICAL POSITION control so that the waveform at the emitter of Q5493 (if present) has an amplitude of approximately 250 millivolts.

Erratic Sweep

If the free-running sweep on the crt is erratic, check the waveform at the cathode of V6473. If it appears similar to Fig. 5-5, the trouble is in D6473 or the Retrace Offset

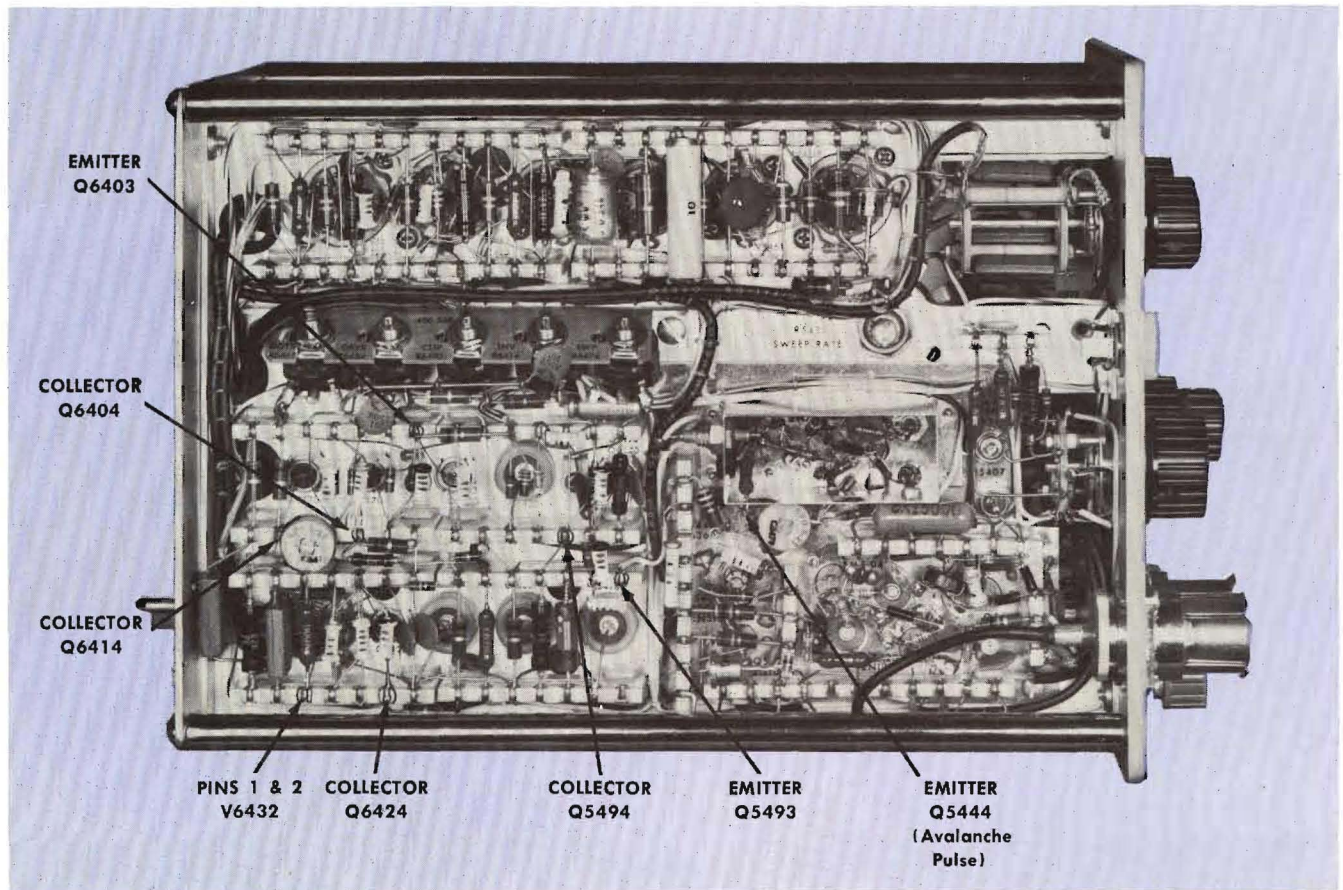

Fig. 5-3. Vertical Channel test points.

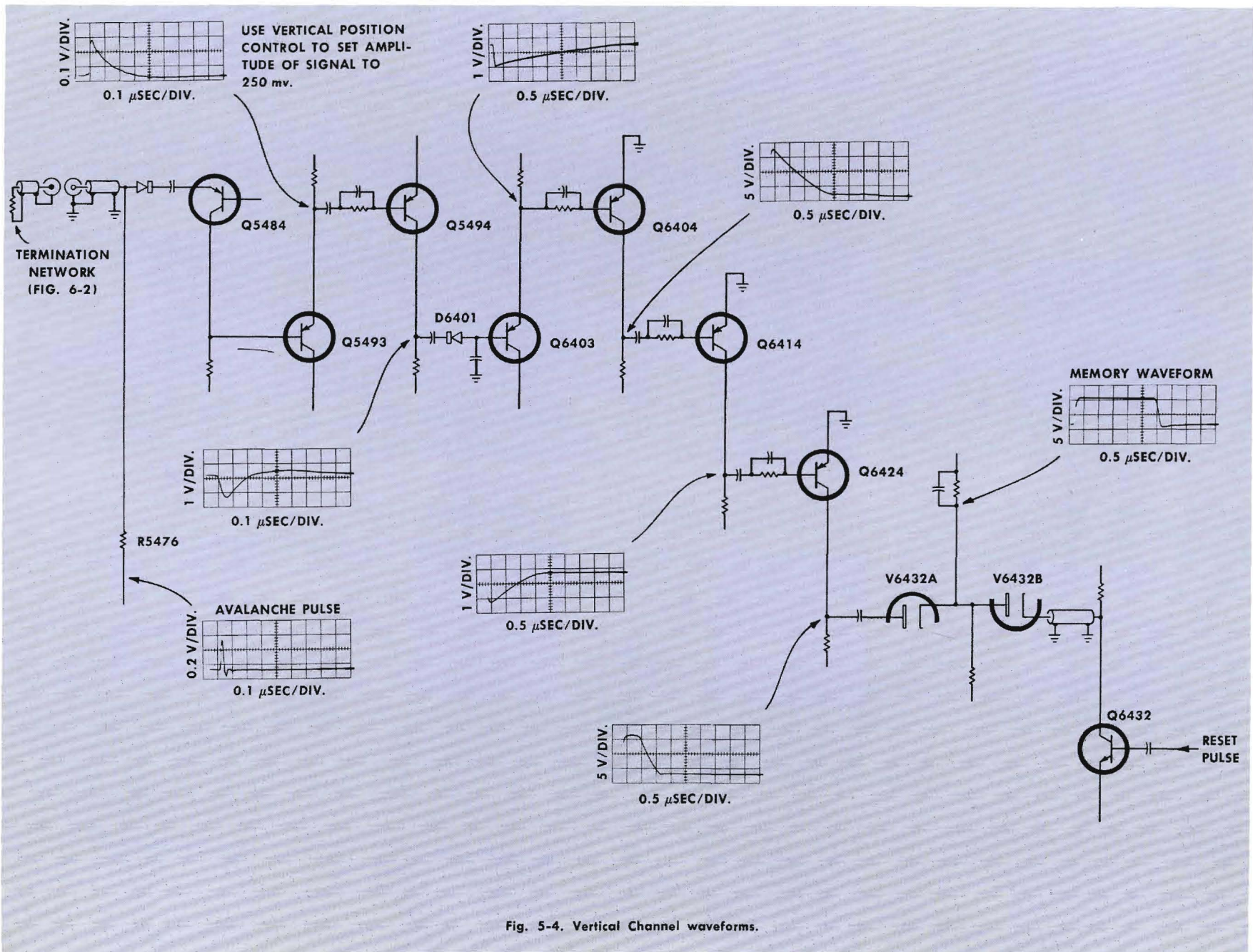

Fig. 5-4. Vertical Channel waveforms.

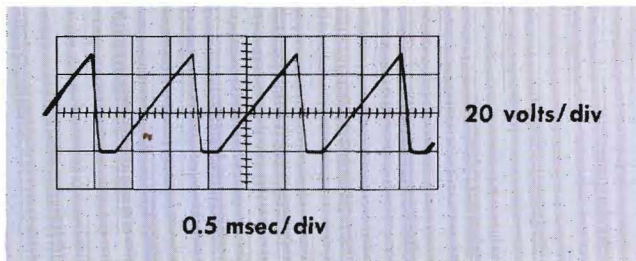

Fig. 5-5. Waveforms at Cathode of V6473 (SAMPLES/DISPLAY switch at 50).

Amplifier. Otherwise, the trouble is elsewhere in the Horizontal Channel.

Abnormally Long Sweep

If the sweep has unaccountably lengthened out to about twice its normal length and the SWP adjustment and the DOTS adjustment must be turned to the extreme end of their ranges to bring the sweep back into calibration, V6452A is probably open. To verify this, check the waveform at the cathode of V6473. If it appears normal except that it has an amplitude of 80 or 90 volts, then V6452A is faulty.

Stationary Bright Spot Somewhere on the Trace.

The Retrace Offset Amplifier Q6444 moves the spot off the right hand side of the screen during the holdoff time of the sweep. If a stationary bright spot appears somewhere within the trace on the screen, this means that the Retrace Offset Amplifier is not operating properly. The waveform at the TO EXT. HORIZ. connector should be similar to the one shown in Fig. 5-6.

Lowered Vertical Sensitivity

If, when a pulse is applied to the Type N Unit, the vertical sensitivity is found to be less than the specified 10 millivolts per centimeter of deflection, check the waveforms

shown in Fig. 5-4, noting especially the amplitude at each stage. This should enable you to isolate the stage in which the loss in amplitude is occurring.

Dots Appear As Vertical Lines

If the dots on the screen appear as short vertical lines (at low repetition rates), first try to correct this by adjusting the FOCUS and ASTIGMATISM controls. If this fails to correct the trouble, check to see if the length of the vertical lines varies with the setting of the VERTICAL POSITION control. If it does, then there is a trouble in the Memory Circuit of the Vertical Channel which has reduced the discharge time constant of C6435 and C6436. If the length of the vertical lines does not vary with the setting of the VERTICAL POSITION control, then the crt unblanking pulse from the Pulse Generation Channel is not correct. This can be verified by checking the waveform at the lower end of T5460 as shown in Fig. 5-1.

NOTE

At high repetition rates and 50 samples per display, amplitude noise can cause the dots to be elongated vertically as much as two millimeters. This is normal and cannot be eliminated. (Compare the dots of Fig. 2-7, at 720 cps, with those of Fig. 2-6, at 100 kc.)

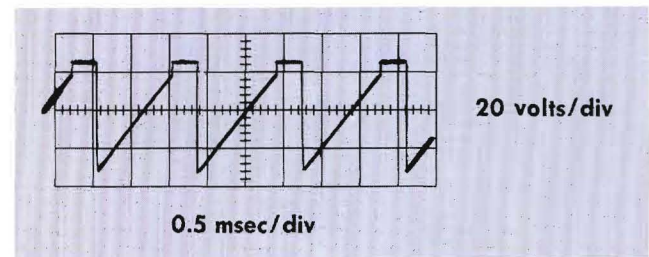
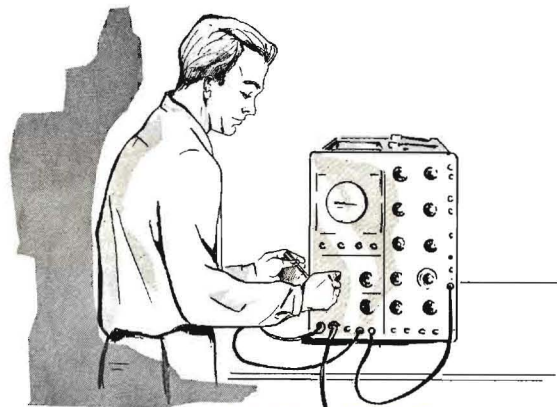

Fig. 5-6. Waveform at TO EXT. HORIZ. connector (SAMPLES/DISPLAY switch at 50).

NOTES

SECTION 6

CALIBRATION PROCEDURE



INTRODUCTION

The procedure contained in this section is provided to enable you to calibrate and check the operation of the Type N Sampling Plug-In Unit. In addition, this section may be used to isolate troubles occurring within the unit.

Apparent troubles in the unit are often the result of improper calibration of one or more circuits. Consequently, calibration checks should be an integral part of any troubleshooting procedure. Abnormal indications occurring during the calibration checks will often aid in isolating troubles to a definite circuit or stage.

In the instructions that follow, the steps are arranged in proper sequence for a complete calibration of the instrument. Each numbered step contains the information required to make one check, one adjustment, or a series of related adjustments or checks. The steps are arranged so that unnecessary repetition of certain checks is avoided. In order to identify the two oscilloscopes used to perform the calibration steps, the test oscilloscope is referred to as "test oscilloscope", and the oscilloscope with the Type N Unit is called "oscilloscope". Whenever possible, the settings of the test oscilloscope controls are given in a separate paragraph for easy identification.

In each calibration step only the required information is given. Detailed instructions pertaining to normal operation of the instrument are not included. If you are in doubt as to the proper operation of the controls, refer to the Operating Instructions.

Controls not mentioned in a particular calibration step are assumed to be in the positions they were in during the previous step. All test equipment used in any particular step should remain connected at the end of that step unless you are otherwise instructed.

If you suspect that the unit is out of calibration, but you are not aware of which particular adjustment will correct the difficulty, it is usually best to run through the entire calibration procedure. In this way you can be certain that the unit is properly calibrated without resorting to a method of random experimentation.

The location of each test point and internal adjustment is shown in Figures 6-3 and 6-4.

EQUIPMENT REQUIRED

The following equipment or its equivalent is required to perform a complete calibration of the Type N Sampling Plug-In Unit.

- (1) Test Oscilloscope, Tektronix Type 540-Series with Type L Plug-In Unit and 10X probe or equivalent. The following specifications are required: bandpass, dc to 30 mc; vertical deflection factors, .005 to 20 volts/cm.
- (2) Tektronix Type 110 Pulse Generator and Trigger Take-off System, or Tektronix Type 111 Pretrigger Pulse Generator or equivalent having the following specifications: a pulse risetime of 0.5 nsec or less, a pulse width of approximately 40 nsec, an output impedance of 50 Ω , a pulse repetition rate equal to or greater than 700 cps, and a +10-volt regenerated trigger, 225-nsec wide.
- (3) Tektronix Type 113 Delay Cable Unit or equivalent to provide 60 nsec of delay time. Risetime of the delay cable should be ≤ 0.1 nsec. (Not needed with Type 111 Pretrigger Pulse Generator).
- (4) Tektronix 1, 2, 5 and 10 nsec/cycle Timing Standard.
- (5) VTVM (preferred) or a 20,000 Ω /volt dc voltmeter.
- (6) The following coaxial cables are required:
 - a. Two 2-nsec cables.
 - b. One 5-nsec cable.
 - c. Two 10-nsec cables.
 - d. One 20-nsec cable.
 - e. One unblanking cable.
 - f. One external horizontal cable.
- (7) 100-mv, 50 Ω Calibrator Adapter for the Type N Unit to provide a properly terminated 100-mv signal from the square-wave calibrator (or construct unit shown in Fig. 6-1).

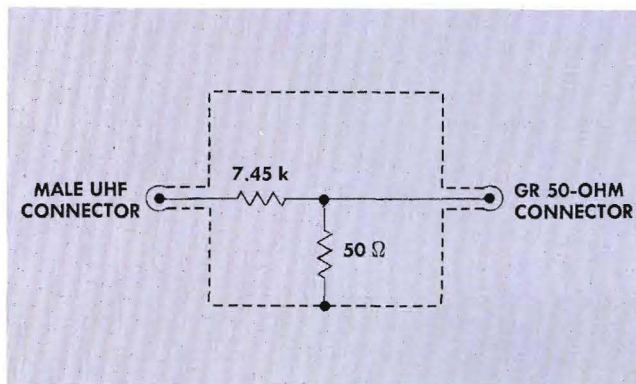

Fig. 6-1. 100-mv 50 Ω Calibrator Adapter circuit.

Calibration Procedure — Type N

- (8) The following 50 Ω attenuator pads are required:
 - a. One 5X attenuator.
 - b. One 10X attenuator.
- (9) One terminated pigtail (50 Ω impedance) made up of following parts; one 8-inch RG-58A/U cable; one GR (General-Radio) 50-ohm connector; two 100 Ω $\frac{1}{2}$ -w resistors. Assemble according to circuit shown in Fig. 6-2.
- (10) Two test leads, 18" long.
- (11) Capacitor, .001 μ f.
- (12) Insulated alignment tool, 1 $\frac{1}{2}$ -inch shank, Tektronix Part No. 003-000 or equivalent.

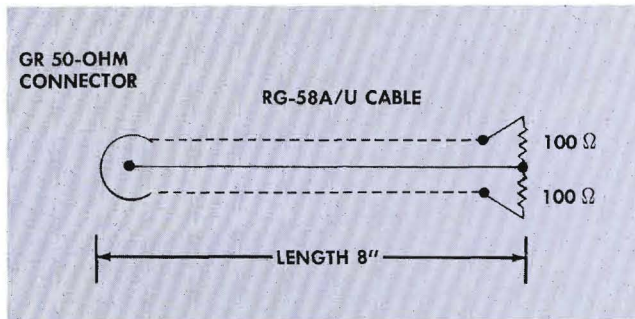

Fig. 6-2. 50 Ω terminated cable circuit.

PRELIMINARY PROCEDURE

CAUTION—When connecting test equipment to the test points indicated in this procedure, be careful not to short the test leads to nearby wiring. The transistors and the other components can be easily damaged.

1. Oscilloscope DC Power Supplies

The -150 -, $+100$ -, $+225$ -, and $+350$ -volt oscilloscope power supplies are checked to insure that proper dc operating voltages are supplied to the Type N Unit. If the power supply voltages are measured in the N Unit, the reading will be lower than the voltages stated above due to the decoupling circuits which are connected in series with the unit. The exact readings are given at the last part of this step.

To measure the power supply voltages, first remove the left side cover from the oscilloscope. Next, insert the Type N Unit into the vertical plug-in compartment of the oscilloscope.

Connect the cable from the TO EXT. HORIZ. connector to the oscilloscope External Horizontal Input connector. Disconnect the ground strap from the CRT CATHODE connector at the rear of the oscilloscope. Connect the unblanking transformer cable to the CRT CATHODE and GROUND connectors. If the oscilloscope has a CRT CATHODE SELECTOR switch, place it in the EXTERNAL CRT CATHODE position. Place the AMPLITUDE (or SQUARE-WAVE) CALIBRATOR switch at 1 volt and connect a test

lead from the CAL. OUTPUT connector through the .001- μ f capacitor to the Type N TRIGGER INPUT connector. (Alternatively, you can connect a regenerated trigger from the Type 110 or a pretrigger from the Type 111, or equivalent, through a 10-nsec cable to the REGENERATED TRIGGER INPUT connector.) Connect the pigtail, shown in Fig. 6-2, to the SIGNAL INPUT connector on the Type N to provide a working load. Rotate the TRIGGER SENSITIVITY control fully clockwise. Connect the oscilloscope to a line source of 105 to 125 VAC if the oscilloscope is wired for 117-volt operation (210-250 VAC if wired for 234-volt operation). Turn on the oscilloscope power switch. After allowing time for the delay relay to energize, connect the dc voltmeter successively to the -150 -, $+100$ -, $+225$ -, and $+350$ -volt test points shown in Fig. 6-3. Be sure your voltmeter is accurate. The readings should be as follows: -146.2 volts ($\pm 2\%$), $+98.8$ volts ($\pm 3\%$), $+224$ volts ($\pm 3\%$), and $+349.6$ volts ($\pm 3\%$) respectively. Disconnect the voltmeter leads.

2. N-Unit 20-Volt Power Supplies

The purpose of this step is to measure the output and ripple voltages of the $+20$ -volt and -20 -volt dc supplies.

NOTE

The accuracy of the 20-volt supplies in the Type N Unit depends on the accuracy of the $+100$ -volt supply in the oscilloscope. Be sure the latter supply is within tolerance; see step 1.

Rotate the TRIGGER SENSITIVITY control fully counterclockwise. Connect the dc voltmeter to the $+20$ - and -20 -volt test points shown in Fig. 6-3. The voltage reading should be $+20$ volts (± 2 volts) and -20 volts (± 2 volts), respectively. Disconnect the voltmeter.

Set the oscilloscope trigger controls so the internal sweep circuits are not running. Use the test oscilloscope and probe to measure the amount of ripple present at the 20-volt test points shown in Fig. 6-3. Typical ripple amplitude is less than 10 mv. Disconnect the probe.

3. Free-Running Operation

Set the HORIZONTAL DISPLAY switch on the oscilloscope to the external-horizontal position (EXT., EXT. HORIZ., EXT. SWEEP, etc., depending on instrument) and set the external-horizontal attenuator switch to the X10 or 10 volts/cm position (switch nomenclature will vary with instrument types). Set the following controls on the test oscilloscope: TIME/CM to 10 μ SEC, vertical VOLTS/CM to .2, and the vertical input selector (coupling) to AC.

Rotate the TRIGGER SENSITIVITY control fully clockwise. Check to see that the trace is displayed on the screen. Connect the probe of the test oscilloscope to the junction of pins 1 and 2, V6432 (Fig. 6-3). Adjust the test oscilloscope trigger controls for a stable display. Adjust the REP. RATE LIMIT adjustment R5407 (Fig. 6-4) for an output frequency of 120 kc (12 cycles displayed on the 10-centimeter graticule). Then turn the adjustment counterclockwise until the output frequency is 100 kc (one cycle per centimeter). Disconnect the probe.

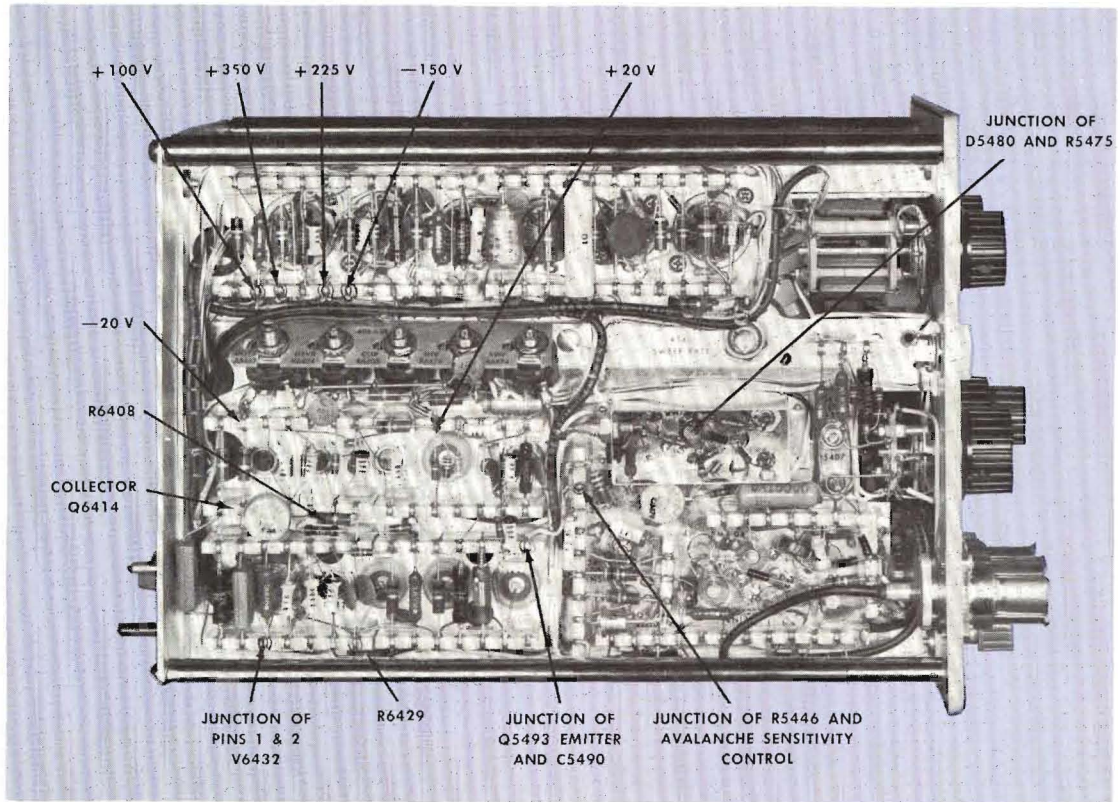

Fig. 6-3. Location of the Type N Unit test points.

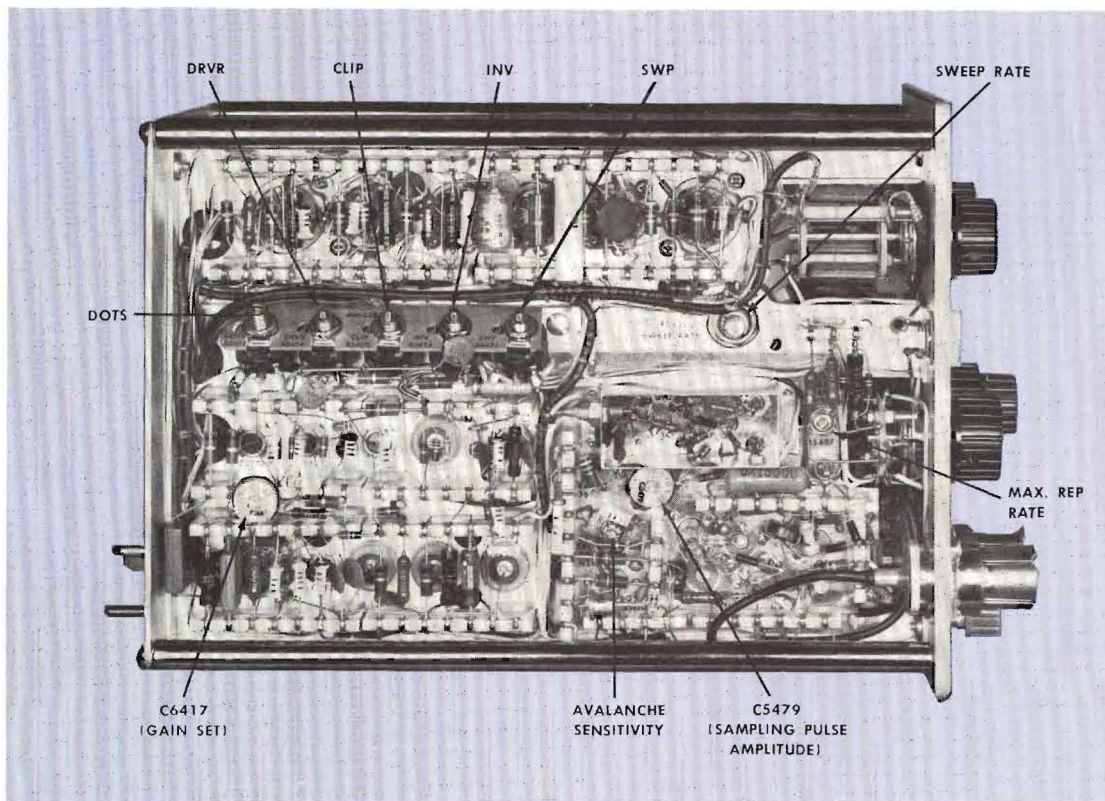

Fig. 6-4. Location of the Type N Unit internal adjustments.

4. Horizontal Deflection Factor

The length of the horizontal sweep is set at 10 centimeters by means of the Sweep Length control R6474.

To make this adjustment disconnect the external horizontal cable from the oscilloscope External Horizontal Input connector. Connect 50 volts of Calibrator signal to the External Horizontal Input connector. Check to see that the TRIGGER SENSITIVITY control is clockwise to free-run the sweep. Adjust the oscilloscope external horizontal variable control so the horizontal deflection is exactly 10 cm. (The SLOPE toggle switch on the Type 535 and 545 oscilloscope must be in the — position for correct signal polarity). The external horizontal variable control should be left in this position throughout the rest of the calibration procedure.

Disconnect the Calibrator signal from the External Horizontal Input Connector. Connect 1 volt of Calibrator signal to the TRIGGER INPUT connector on the Type N Unit through the .001- μ f capacitor. Reconnect the external horizontal cable to the oscilloscope External Horizontal Input connector. Place the SAMPLES/DISPLAY switch at 100. Adjust the TRIGGER SENSITIVITY control to trigger (but not free run) the sweep. Set the SWP control (R6474) for a horizontal deflection of exactly 10 cm, and adjust the HORIZONTAL POSITIONING control to center the trace within the graticule.

5. Dots Adjustment

This adjustment determines the number of samples per display and is set to agree with the front-panel SAMPLES/DISPLAY control setting.

To make this adjustment, first set the oscilloscope External Horizontal Attenuator switch at X1 (i.e., increase the sensitivity ten times to obtain a deflection factor of .5 volts/cm.) Next, adjust the DOTS control (R5467) to obtain one dot per centimeter. Return the external horizontal attenuator switch to the X10 position.

6. Preset Avalanche Adjustment

The operation of the avalanche and comparator (fast ramp generator) circuits are checked first in this step before a final setting is made.

Set the test oscilloscope controls as follows: TRIGGER SLOPE switch at +EXT., TIME/CM switch at .5 μ SEC, vertical VOLTS/CM switch at 1, vertical input selector switch at DC.

Connect a test lead from the CAL. OUT connector to the test oscilloscope external Trigger Input connector. Connect the probe to the junction of R5446 and the AVALANCHE SENSITIVITY control (R5447). Rotate the AVALANCHE SENSITIVITY control fully counterclockwise. Rotate the AVALANCHE SET control (R5442) fully counterclockwise and then slowly clockwise and stop just before the signal (sampling pulse) begins to free run. Free running is indicated by a self-initiated sweep that is not triggered by the trigger input signal. If the signal does not free run, set the AVALANCHE SENSITIVITY control for the most stable output.

CALIBRATE VERTICAL CHANNEL

7. C5479 Adjustment

C5479 sets the amplitude of the avalanche sampling pulse applied to the input of the vertical amplifier channel.

Set the test-oscilloscope TIME/CM switch to .1 μ SEC, the VOLTS/CM switch to .1, and the vertical input selector switch to AC.

NOTE

Rotate the VERTICAL POSITION control to the center of its range and leave the control at this position through step 10.

Connect the probe to the Q5494 collector. Adjust the triggering controls on the test oscilloscope to obtain a stable display. Rotate C5479 to obtain a 1.8-volt amplitude signal. Disconnect the probe.

8. Driver Adjustment

The Driver adjustment sets the bias on the driver transistor Q6424.

To make this adjustment connect the dc voltmeter across Q6424 collector load resistor, R6429. Adjust the DRVR. control for a reading of 3 volts on the meter.

9. Inverter Adjustment

The Inverter adjustment sets the bias on the inverter transistor Q6414.

To make this adjustment connect the dc voltmeter between Q6414 collector and ground. Rotate the INV. control (R6414) counterclockwise to obtain a minimum reading on the meter. Then rotate the INV. control clockwise to increase the meter reading by 1 to 2 volts. If the meter now reads more than—5 volts, replace the inverter transistor and repeat this step.

10. Preliminary Clipper and Vertical Position Limit Adjustments

This step is performed to establish the dynamic operating range of the clipper stage and to center the operating range of the vertical channel.

NOTE

Type 532 and Type 536 Oscilloscopes have graticules with more than 6 vertical divisions. When setting the VERTICAL POS. LIMIT and CLIP adjust controls with these oscilloscopes, the "top" and the "bottom" of the graticule are considered to be 3 divisions above and 3 divisions below the centerline, respectively.

To perform this step rotate the VERTICAL POS. LIMIT control (R6439) counterclockwise until the trace is at the bottom graticule line. Rotate the CLIP control (R6405) clock-

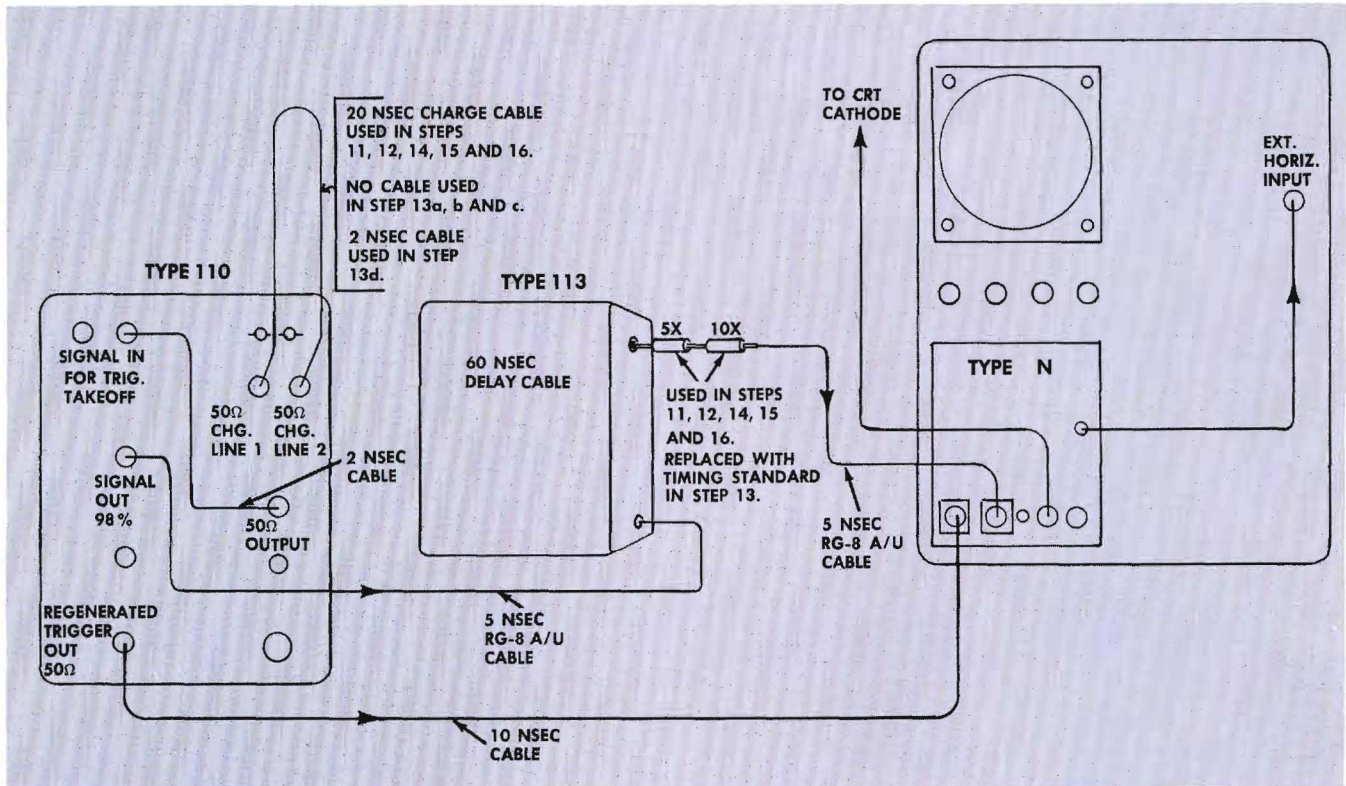

Fig. 6-5. Cable connections required to calibrate the Type N Unit when the Type 110 Pulse Generator and Trigger Takeoff System is used.

wise until the trace cannot be moved up any further. Rotate the VERTICAL POS. LIMIT control counterclockwise to keep the trace at the bottom of the screen. In a properly operating unit, the dots making up the trace will elongate vertically when the CLIP control will not position the trace any higher on the screen. (This effect is due to the driver transistor, Q6424, charging the memory capacitors, C6435 and C6436, to the holdoff bias on the reset diode, V6432). Set the saturated trace four centimeters above the bottom graticule line on the screen by means of the VERTICAL POS. LIMIT control. Rotate the CLIP control counterclockwise to position an unsaturated trace 4 centimeters below the saturated level. Reposition the unsaturated trace to the center of the graticule by means of the VERTICAL POS. LIMIT control. Disconnect the two test leads, the .001- μ f capacitor and the terminated pigtail.

11. Display Linearity

The linearity of the display is checked when a signal such as that available from the Type 110 Pulse Generator and Trigger Takeoff System, or from the Type 111 Pre-trigger Pulse Generator, is applied to the input of the Type N Unit. This step is also performed to aid you in checking the results of your previous adjustments.

Fig. 6-5 shows how the cable connections are made when the Type 110 is used as a signal and trigger source. You

will note that in this step a 20-nsec cable is connected from the 50 Ω CHG. LINE 1 connector to the 50 Ω CHG. LINE 2 connector; the 5X and 10X attenuator pads are connected in series at the output of the Type 113 in order to attenuate the signal produced by the Type 110. When using the Type 111 as a signal and trigger source, use appropriate attenuators to limit the signal being applied to the Type N Unit.

Set the Type 110 Pulse Amplitude controls to provide pulses 0.5 volt in amplitude. Set the Type 110 Trigger Takeoff controls so that one 10X amplifier is switched in and the attenuators are switched out of the circuit. At the output of the 10X amplifier, a 1-volt triggering signal will be coupled directly to the trigger regenerator. Rotate the Type N TRIGGER SENSITIVITY control fully counterclockwise. Set the Type 110 TRIGGER SENSITIVITY control for triggered operation of the Type N Unit. Adjust the VERTICAL POSITION and DELAY controls to display the pulse on the oscilloscope screen. Adjust the Type 110 AMPLITUDE control to produce a 1-cm-high pulse on the screen. The signal should remain at this amplitude ($\pm 10\%$) when positioned vertically over the 6-cm range on the Type 530-series oscilloscope (center 6-cm or 6-div. range on a Type 532 or 536 oscilloscope) when the sensitivity of the Type N Unit is correct (see step 15). The amplitude should remain within $\pm 5\%$ on a 4-cm-high graticule (except for the Type 580-series oscilloscopes, which should be $\pm 20\%$) if the linearity of the Type N Unit is correct.

12. Final Adjustment of Avalanche Set and Sensitivity

These adjustments are made to select an optimum balance between minimum delay time and noise of the avalanche generator.

Set the Type 110 Pulse Amplitude controls so that the output pulse amplitude is 2 volts. Set the Trigger Takeoff controls so that the $\div 3.16$ attenuator is switched into the circuit. This causes a 1.3-volt triggering signal to be coupled to the trigger regenerator. Rotate the Type N TRIGGER SENSITIVITY control fully counterclockwise. Set the Type 110 TRIGGER SENSITIVITY control for triggered operation of the Type N Unit. Adjust the VERTICAL POSITION and DELAY controls to display the pulse on the oscilloscope screen. Slowly rotate the AVALANCHE SET control in the direction that will cause the displayed pulse to move to the right as far as possible without introducing a large amount of noise. Next, rotate the AVALANCHE SENSITIVITY control clockwise until the avalanche generator free runs (trace breaks up); then rotate the control counterclockwise to stop the free running and to move the displayed pulse as far to the right as possible while retaining a minimum amount of noise.

Not all 2N636 transistors exhibit the same characteristics. If either the AVALANCHE SET or the AVALANCHE SENSITIVITY control seems insensitive when adjusted, set the insensitive control fully counterclockwise. Adjust the more sensitive control to position the pulse as far to the right as possible, while retaining a low level of noise as explained above. If, while adjusting either control, the trace moves down suddenly, rotate the control counterclockwise to a point just before the discontinuity occurs. Repeat steps 7, 10, and 11.

HORIZONTAL TIME CALIBRATION

13. Timing Rates and Delay Range

The purpose of this step is to accurately set the 1-, 2-, 5- and 10-nanosecond per centimeter sweep rate.

As demonstrated in Fig. 6-5, no charge line is connected from 50 Ω CHG. LINE 1 connector to 50 Ω CHG. LINE 2 connector during parts a, b and c of this step. A 2-nsec cable is connected during part d. If the Type 111 is used in place of the Type 110, a 10-nsec charge cable is connected to its CHARGE LINE connector during parts a and b of this step; no charge line is needed during parts c and d. The Timing Standard is connected in place of the 5X and 10X attenuator pads. Place the NANOSEC/CM switch on the Type N Unit at 1 and the SAMPLES/DISPLAY switch at 200. Set the Type 110 Pulse Amplitude controls for 25 volts output. Set the Trigger Takeoff controls so that the $\div 3.16$ attenuator is switched in and the 10X amplifiers are switched out of the circuit. This allows a 1.5-volt trigger signal to be applied to the trigger regenerator. Adjust the Type 110 TRIGGER SENSITIVITY and the Type N DELAY controls to display the timing waveform. The first cycle or so of the waveform may be distorted due to the signal actuating the Timing Standard. If so, add delay with the DELAY

control. For convenience, the waveform displayed at the right side of the graticule should be approximately 1 to 2 cm in amplitude (maximum amplitude obtained from the Type 111-Timing Standard combination is approximately 0.5 to 1 cm during the 1 NANOSEC/CM switch setting). Make certain that the timing waveform dies smoothly and is not re-excited by reflections to cause uneven timing. The proper amplitude can be obtained by using the DELAY control to position the waveform to the left or to the right or by decreasing the Type 110 output pulse amplitude.

First, check the Type N sweep-rate timing on all ranges according to the information in Table 1. The display is checked for timing from the one centimeter to the nine centimeter horizontal width of the graticule. If the timing is incorrect on any range, adjust the SWEEP RATE control (R5431) to obtain the best possible timing on all ranges. Maximum allowable error on any range is $\pm 3\%$ of the nominal value.

To check the range of the DELAY controls, set the NANOSEC/CM switch to 10 and the DELAY controls fully clockwise. Set the switch on the Timing Standard to 10. Rotate the DELAY controls slowly counterclockwise and count the number of cycles which pass any given point on the graticule. The range of the DELAY controls should be great enough to cause at least 20 cycles of the displayed waveform to pass this point.

TABLE 1

STEP *13	TIMING STANDARD SWITCH SETTING	TYPE N UNIT NANOSEC/CM SWITCH SETTING	NUMBER OF CYCLES PER CENTIMETER
a	1	1	1
b	2	2	1
c	5	5	1
d	10	10	1

* No charge cable is connected from 50 Ω CHG. LINE 1 to 50 Ω CHG. LINE 2 during parts a, b and c; a 2-nsec charge cable is connected during part d.

14. Check Risetime

The risetime is measured from the 10% point to the 90% point on the rising portion of the pulse. The Type 110 is recommended for this step to obtain an accurate risetime measurement. If the Type 111 is used, the overall risetime of the system should be approximately 0.8 nanosecond.

To make this measurement, first replace the 2-nsec charge cable (used in step 13) with a 20-nsec cable. Then replace the Timing Standard with the 5X and 10X attenuator pads connected in series. Adjust the Type 110 output pulse amplitude for approximately 4 volts output and set the Trigger Takeoff controls to couple the trigger signal directly to the trigger regenerator. Adjust the Type 110 TRIGGER SENSITIVITY control to trigger the Type N sweep. Adjust the Type 110 pulse amplitude for exactly 4 cm of vertical deflection as observed on the oscilloscope. Place the NANOSEC/CM switch at 1. Horizontally position the rising portion of the display to the center of the graticule by means of the DELAY control. Observe the points on the rising portion of the displayed pulse where the vertical deflection

is 4 millimeters from the bottom of the pulse and 4 millimeters from the top of the pulse. These two points are the 10% and 90% points on the rising portion of the pulse. The horizontal distance between these two points multiplied by 1 nanosecond per centimeter is the risetime of the "system". (The "system" includes the Type 110, Type 113 and the Type N). The risetime of the system should be approximately 0.6 nanosecond.

If the measured risetime is greater than 0.6 nanosecond (between 0.6 and 0.8 nanosecond), first try to improve the risetime by setting the back bias on the Interrogating Diode, D5480, to 0.75 volt. To obtain this voltage reading, connect the dc voltmeter to the junction of D5480 and R5475 and rotate the VERTICAL POSITION control until the reading is 0.75 volt. Rotate the CLIP control to vertically center the display. Recheck the risetime. If it is still over 0.6 nanosecond, decrease the waveform of step 7 to 1.5 volts. Reset the CLIP control to center the display again. Repeat the risetime check. If the risetime has not improved, replace the avalanche transistor, Q5444, and repeat steps 6, 7, 11, 12, 14, 15 and 16. (The test oscilloscope may be triggered internally [+ or -INT.] instead of externally when repeating step 7.)

Changing the avalanche transistor may change the effective delay through the Pulse Generation Channel. If it does, and you desire to maintain the minimum delay standards of the Type N Unit, you will need to change the value of R5426B. To determine if it is necessary to change the value of R5426B, apply a fast-rising signal to the Type N Unit with an appropriate trigger 40 or 45 nanoseconds ahead of the signal, as specified. (Fig. 2-3 shows one method of connecting the signal and trigger properly for this purpose.) Set the NANOSEC/CM switch to 10 and the DELAY controls fully clockwise. The leading edge of the pulse should now appear about one centimeter from the left-hand edge of the graticule. If the leading edge of the pulse is significantly more than one centimeter (1.5 centimeters or more) from the left-hand edge of the graticule, decrease the value of R5426B. If the leading edge of the pulse is significantly less than one centimeter (0.5 centimeter

or less) from the left-hand edge of the graticule, increase the value of R5426B.

FINAL CALIBRATION OF VERTICAL CHANNEL

15. Gain Adjustment

This adjustment accurately sets the input signal sensitivity of the Type N at 10 mv per centimeter.

Disconnect the cable from the SIGNAL INPUT connector. Connect a 5X attenuator pad to the SIGNAL INPUT connector. Connect a 5-nsec cable from the 5X attenuator through a 100-mv calibrator adapter to the CAL. OUT connector on the oscilloscope. Set the AMPLITUDE (SQUARE-WAVE) CALIBRATOR at 50 VOLTS. The calibrator waveform displays two traces on the screen. Adjust the GAIN SET capacitor, C6417, until the traces are 2 cm apart. If the traces move off the screen, rotate the CLIP control to bring the display onto the screen. Disconnect the 5X attenuator from the SIGNAL INPUT connector. Disconnect the 100-mv calibrator adapter (with cable attached) from the CAL. OUT connector.

16. Final Clipper and Vertical Position Limit Adjustments

This last step is performed by first connecting the terminated pigtail to the SIGNAL INPUT connector and then repeating step 10. When repeating this step, the regenerated trigger can be left connected to the Type N Unit REGENERATED TRIGGER INPUT connector instead of re-connecting a signal from the calibrator to use as a trigger signal.

NOTE

If the Type N Unit is inserted into another oscilloscope after completing this step, it is desirable to check the setting of the VERTICAL POS. LIMIT control according to the information provided in the Operating Instructions section of this manual.

NOTES

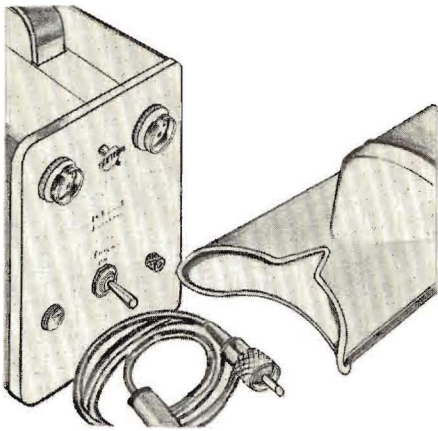

ACCESSORIES

CABLES AND ATTENUATORS

CRT unblanking cable, 60" long, with 3-to-1 step-up transformer on oscilloscope end (for applying crt unblanking signal from Type N Unit to crt cathode).

Part No. 012-052 \$10.00

Horizontal amplifier cable, 18" long, banana-type plug on both ends (for applying staircase sweep from Type N Unit to external horizontal amplifier).

Part No. 012-054 \$1.50

Master-slave patch cord (for applying external time-sweep voltages to the Type N Unit, or synchronizing the time bases of two N Units), approximately 16" long, miniature phone connectors.

Part No. 012-055 \$3.75

50-ohm attenuator, 10 to 1 voltage ratio, GR connectors.

Part No. 017-001 \$20.00

50-ohm attenuator, 5 to 1 voltage ratio, GR connectors.

Part No. 017-002 \$20.00

50-ohm attenuator, 2 to 1 voltage ratio, GR connectors.

Part No. 017-003 \$20.00

Minimum-loss pad, 125 ohms to 50 ohms-GR connector.

Part No. 017-008 \$25.00

50-ohm Terminating Resistor, 2 watt, GR connectors.

Part No. 017-014 \$12.50

50-ohm 10-nanosecond cable, RG-58A/U, 80" long, GR connectors.

Part No. 017-501 \$9.00

50-ohm 5-nanosecond cable, RG-8A/U, 40" long, GR connectors.

Part No. 017-502 \$10.00

50-ohm 1-nanosecond pigtail, RG-58A/U, 8" long, GR connectors.

Part No. 017-503 \$5.00

50-ohm 20-nanosecond cable, RG-8A/U, 157" long, GR connectors.

Part No. 017-504 \$12.00

50-ohm 2-nanosecond cable, RG-58A/U, 17" long, GR connectors.

Part No. 017-505 \$9.00

50-ohm 9-nanosecond charge cable, RG-58A/U, GR connector one end; other end open.

Part No. 017-506 \$6.50

AUXILIARY EQUIPMENT

TYPE 110 PULSE GENERATOR AND TRIGGER TAKEOFF SYSTEM

PULSE GENERATOR

- Risetime—Less than 0.25 nanosecond.
- Minimum Pulse Length—Approximately 0.5 nanosecond.
- Repetition Rate—670 to 770 cps; may be synchronized at 720 cps with line frequency.
- Output Impedance—50 ohms.

TRIGGER TAKEOFF SYSTEM

- Input Impedance—50 ohms.
- Output Impedance—50 ohms.
- Input Signals Through Takeoff System—20 mv to 50 volts in amplitude.
- Direct External Trigger Input—4 mv to 10 volts in amplitude.
- Regenerated Trigger Output—+10-volt, 200-nanosecond pulses, with maximum rate of 100 kc.
- Transmission and Reflection Losses—Less than 2.5% of input signal voltage.

GENERAL DESCRIPTION

The Type 110 Pulse Generator and Trigger Takeoff System is, in effect, two separate units in one cabinet.

The Pulse Generator generates pulses 0.5 to 40 nanoseconds in width, 0 to 50 volts in amplitude (amplitude may be further increased by the use of an external voltage source), and 670 to 770 cps in frequency. Pulses up to 300 nanoseconds in width can be generated at frequencies of 335 to 385 cps. Risetime of the pulses is less than 0.25 nanosecond. Pulse width is varied by the use of charge lines of varying lengths. Unequal charge lines may be used to produce alternate pulses of different lengths up to 40 nanoseconds. External charge voltages may be used to produce alternate pulses of different amplitudes.

The Trigger Takeoff System taps off a portion of a signal and attenuates or amplifies it to provide a voltage suitable for triggering either an external device or its own internal trigger regenerator. This is done with a signal loss of less than 2.5%. An inverter, a $\div 3.16$ attenuator, and two X10 amplifiers provide operation over a range of signal amplitudes from 20 millivolts to 50 volts, either negative or positive. An external input connection is also provided which bypasses the trigger takeoff circuit and allows the use of a signal as small as four millivolts for triggering the trigger regenerator.

VACUUM TUBE AND TRANSISTOR COMPLEMENT

- Voltage Regulator OA2
- Voltage Regulator OB2



- Amplifiers 4 2N700
- Trigger Regenerator 5M04
- Pulser Multivibrator 2 2N270
- Pulser Power Amplifiers 2 2N250
- Voltage Regulator 2N250

MECHANICAL SPECIFICATIONS

- Construction—Aluminum alloy chassis.
- Finish—Photo-etched anodized front and rear panels.
Textured-aluminum cabinet with a vinyl-based blue finish.
- Dimensions—15 $\frac{5}{8}$ " long, 6 $\frac{7}{8}$ " wide, and 10 $\frac{1}{4}$ " high.
- Weight—14 $\frac{1}{2}$ pounds.

Price \$650

- Includes: 1 50-ohm, 2-nsec cable, RG-58A/U, 17" long (017-505)
- 1 50-ohm, 5-nsec cable, RG-8A/U, 40" long (017-502)
- 1 50-ohm, 20-nsec cable, RG-8A/U, 157" long (017-504)
- 1 3-wire power cord
- 1 3-wire adapter

TYPE 111 PRETRIGGER PULSE GENERATOR

Output Pulse—0.5 nanosecond risetime, 2 to 100 nanoseconds in width, 30 to 250 nanoseconds in advance of output pulse (may be used as regenerated trigger for Type N Sampling Plug-In Unit).

Frequency—10 cps to 100 kc free-running; will count down to less than 100 kc from an external trigger source up to 1 megacycle.

GENERAL DESCRIPTION

The Type 111 Pre-Trigger Pulse Generator is a fast-rise pulser which supplies its own triggering signal from 30 to 200 nanoseconds in advance of each pulse. The risetime of the output pulse is 0.5 nanosecond, and its width may be varied from 2 to 100 nanoseconds by the use of charge lines. The trigger is 10 volts in amplitude and 250 nanoseconds in width. In addition to free-running at 10 cps to 100 kc, the Type 111 will also count down to less than 100 kc from an external trigger up to one megacycle.

VACUUM TUBE AND TRANSISTOR COMPLEMENT

Voltage Regulator	0A2
Multivibrator	12AT7
Blocking Oscillators	2 5M04
Avalanche Generators	2 2N636

MECHANICAL SPECIFICATIONS

Construction—Aluminum alloy chassis.

Finish—Photo-etched anodized front and rear panels; textured-aluminum cabinet with a vinyl-based blue finish.

Dimensions—11 $\frac{1}{4}$ " long, 6 $\frac{5}{8}$ " wide, 10 $\frac{3}{8}$ " high.



Weight—8 pounds.

Price \$365
 Includes: 1 50-ohm 10-to-1 attenuator (017-001)
 1 50-ohm 9-nsec charge cable, RG-58A/U, GR connector one end, other end open (017-506)
 1 3-wire power cord.
 1 3-wire adapter

TYPE N SAMPLING PLUG-IN UNIT

Risetime—Approximately 0.6 nanosecond.

Sensitivity—10 mv/cm, with a minimum linear dynamic range of ± 120 mv.

Equivalent Sweep Times—1, 2, 5, and 10 nanoseconds per centimeter.

Sampling Rate—50 cps to 100 kc (will count down from 50 mc trigger rate).

Delay Range—200 nanoseconds less the period of the display.

External Trigger Requirements—0.5 to 2.0 volts amplitude, 1 nanosecond or longer duration, at least 45 nanoseconds in advance of signal to be displayed.

External Regenerated Trigger Requirements—10 volts amplitude, 200 nanoseconds duration, 40 nanoseconds in advance of signal to be displayed.

GENERAL DESCRIPTION

The Type N Sampling Plug In Unit makes possible the accurate display of repetitive pulses with nanosecond

risetimes on any Tektronix plug-in type oscilloscope. By taking successive samples at slightly later times in recurring cycles of the pulse under observation, the Type N reconstructs the pulse on a relatively long time base. The sampling technique provides displays with apparent sweep rates of as little as 100 picoseconds per centimeter. The delay range of 200 nanoseconds including the display permits observation of both leading and trailing edges of any pulse less than 200 nanoseconds in width. Although the pulses must be repetitive, their spacing may vary, provided the minimum spacing is 10 microseconds or more; the spacing may be as small as 20 nanoseconds if the pulses are regularly spaced. (The trigger circuit counts down from 50 mc to 100 kc.)

VACUUM TUBE AND TRANSISTOR COMPLEMENT

Pulse Regeneration Channel	
Trigger Regenerator	SM04
Comparator	SM04
Bootstrap Emitter Follower	2N169A

Accessories Section

Delay Emitter Follower	2N169A
Avalanche Generator	2N636
Delay Blocking Oscillator	2N597
Unblanking Blocking Oscillator	2N601
Reset Amplifier	2N597

Vertical Channel

First Stretcher	2N700
Stretcher Emitter Follower	OC170
X10 Amplifier	OC170
Second Stretcher Emitter Follower	OC170
Clipper	OC170
Inverter	OC170
Driver	OC170
Memory Diode	12AL5

Horizontal Channel

Multivibrator	6AN8
Disconnect Diodes	12AL5
Holdoff CF and DC Feedback CF	12AT7
Charging Diodes	12AL5
Miller Runup	12AU6
Runup Cathode Follower	12AU7
Retrace Offset Amplifier	OC170

Power Supplies

Comparators	2 2N544
Regulator Amplifiers	2 2N270
Series Regulators	2 2N301

MECHANICAL SPECIFICATIONS

Construction—Aluminum alloy chassis

Finish—Photo-etched anodized panel

Weight—7 pounds

Price \$600

Includes: 1 50-ohm 10-to-1 attenuator (017-001)

1 50-ohm 5-to-1 attenuator (017-002)



1 50-ohm 2-to-1 attenuator (017-003)

1 50-ohm 10-nsec delay cable, 80" long (017-501)

1 50-ohm 5-nsec delay cable, 40" long (017-502)

2 50-ohm 1-nsec pigtails, 8" long (017-503)

1 50-ohm crt unblanking cable, 60" long (012-052)

1 50-ohm horizontal amplifier cable, 18" long (012-054)

1 3-wire power cord

1 3-wire adapter

OTHER ACCESSORIES

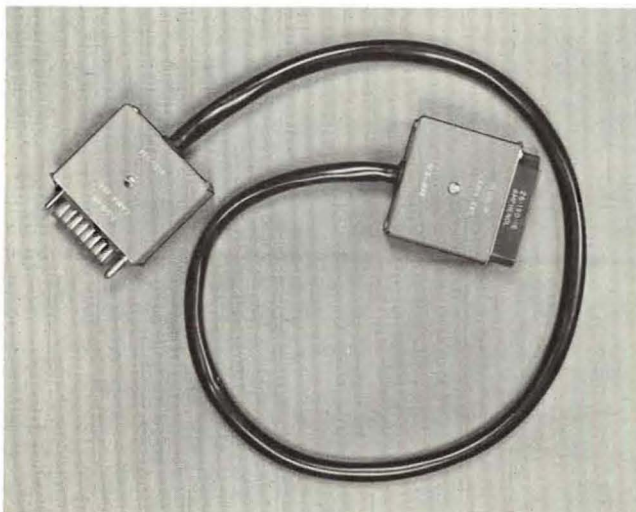

Plug-In Cable Extension—Permits the operation of a plug-in unit completely out of its housing in a Type 530-, 540-, or 550-Series Oscilloscope.

Part No. 012-038 \$15.00



Type EP54 Plug-In Extension—Permits the operation of a plug-in unit partially extended out of its housing in a Type 530-, 540-, or 550-Series Oscilloscope.

Part No. 013-019 \$8.50

Type 81 Plug-In Adapter—Allows any plug-in preamplifier unit for the Type 530-, 540-, and 550-Series Oscilloscopes to be used with the Type 580-Series Oscilloscopes . \$125.00

Calibration Adapter—Converts a 50-volt output from the oscilloscope calibrator to 100 millivolts at 50 ohms impedance, for use in calibrating the gain of the Type N Sampling Plug-In Unit.

Part No. 017-010 \$15.00

Timing Standard—Designed to "ring" at frequencies of 1000 mc, 500 mc, 200 mc, and 100 mc (periods of 1, 2, 5, and 10 nanoseconds) when excited by a fast-rising pulse. It is used in calibrating the NANOSEC/CM switch on the Type N Sampling Plug-In Unit.

Part No. 013-028 \$60.00

Tunnel Diode Risetime Tester—For use with Type N Unit. Tests 1-20 ma diodes with +GATE OUT waveform of oscilloscope, or higher current diodes with external pulse generator such as the Tektronix Type 105 Square-Wave Generator or Type 110 Pulse Generator.

Part No. 013-029 \$50.00

TYPE 113 DELAY CABLE

The Type 113 is a low-loss delay cable which provides a 60-nanosecond delay to a signal applied through it. It has a risetime of 0.1 nanosecond. It is 23 by 23 by 9 inches in size and weighs about 31 pounds \$200.00

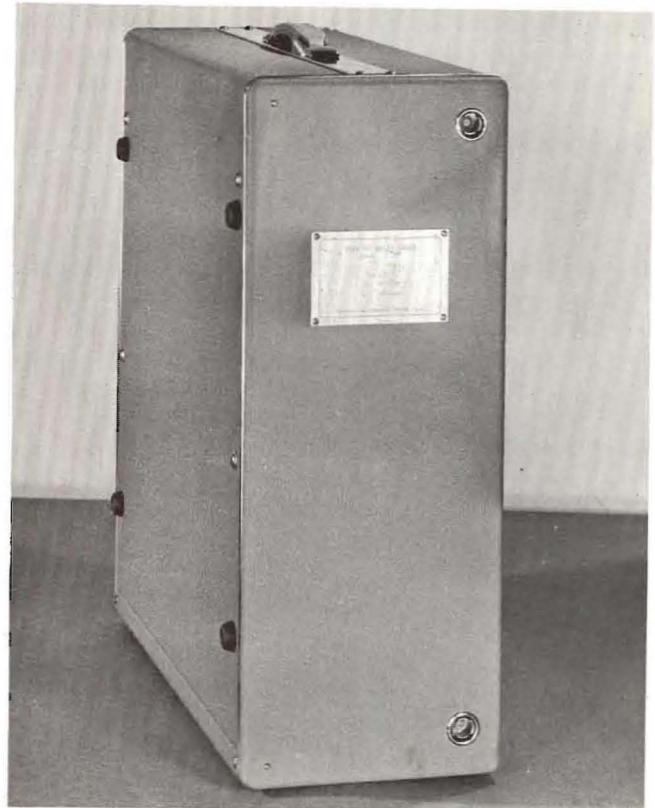



PARTS LIST *and* DIAGRAMS

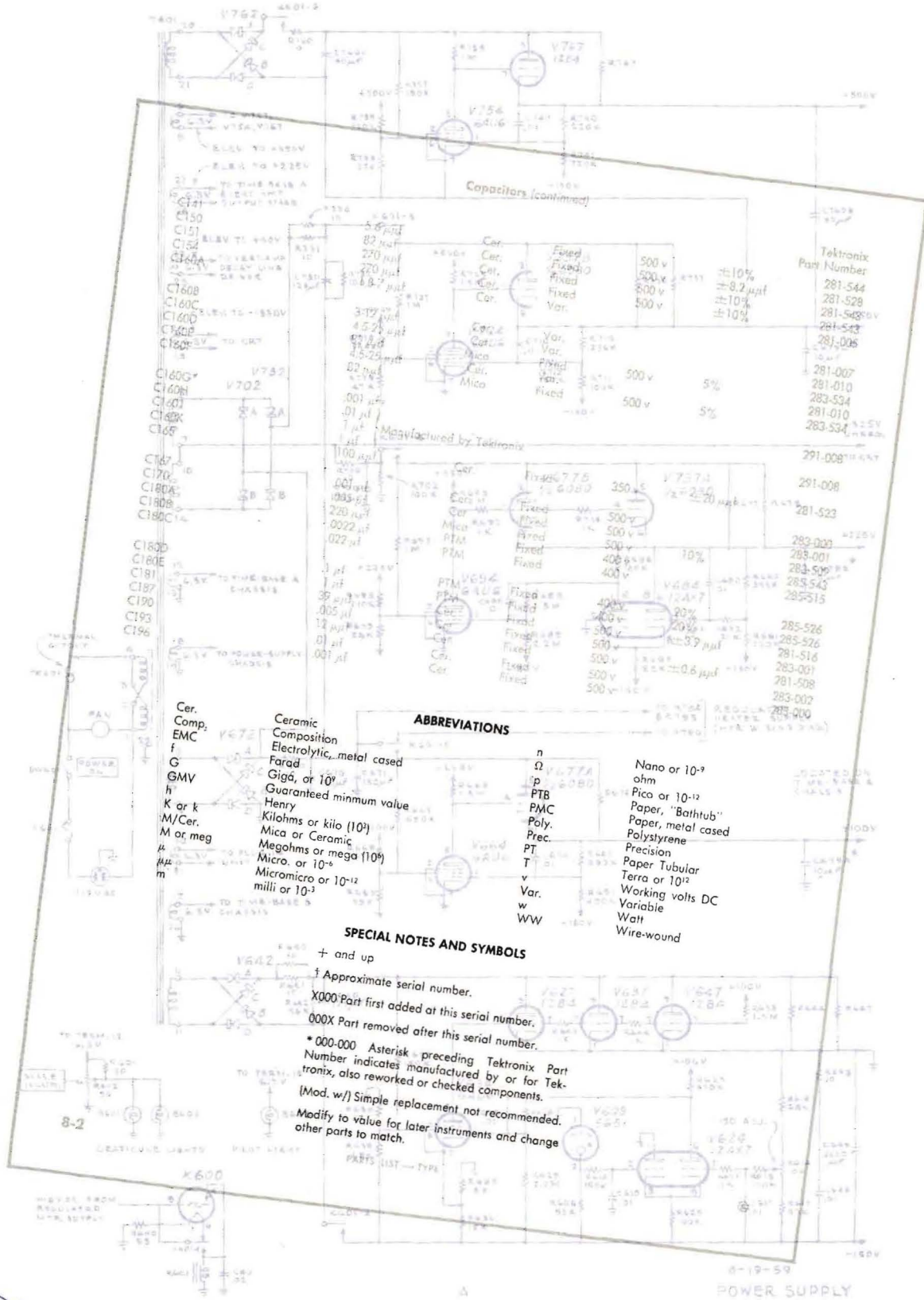

MANUFACTURERS OF CATHODE-RAY OSCILLOSCOPES

HOW TO ORDER PARTS

Replacement parts may be purchased at current net prices from your local Tektronix Field Office or from the factory. Most of the parts can be obtained locally. All of the structural parts, and those parts noted in the parts list "Manufactured by Tektronix", should be ordered from Tektronix.

When ordering from Tektronix include a complete description of the part, and its 6-digit part number. Give the type, serial number, and modification number (if any) of the instrument for which it is ordered.

Structural parts are not listed in the parts list. Their part numbers are usually stamped directly on the metal. If not, a complete physical description of the part will suffice.

If the part which you have ordered has been replaced by a new or improved part, the new part will be shipped instead. Tektronix Field Engineers are informed of such changes. Where necessary replacement information comes with new parts.

Capacitors (continued)

							Tektronix Part Number
C6414		.01 μ f	Cer.	Fixed	150 v		283-003
C6417		3-12 $\mu\mu$ f	Cer.	Var.			281-036
C6418		.01 μ f	Cer.	Fixed	150 v		283-003
C6419		50 μ f	EMT	Fixed	25 v		290-120
C6420		50 μ f	EMT	Fixed	25 v		290-120
C6421		.01 μ f	Cer.	Fixed	150 v		283-003
C6422		25 μ f		Fixed	25 v		290-107
C6423		.01 μ f	Cer.	Fixed	150 v		283-003
C6426		470 $\mu\mu$ f	Cer.	Fixed			281-525
C6427		51 $\mu\mu$ f	Cer.	Fixed	500 v		281-540
C6428		22 $\mu\mu$ f	Cer.	Fixed	500 v		281-511
C6430		.01 μ f	Cer.	Fixed	150 v		283-003
C6432		.0022 μ f	Cer.	Fixed	50 v		283-028
C6435		220 $\mu\mu$ f	Mica	Fixed		5%	283-513
C6436		2000 $\mu\mu$ f	Mica	Fixed	500 v	1%	283-555
C6437		2000 $\mu\mu$ f	Mica	Fixed	500 v	1%	283-555
C6440		470 $\mu\mu$ f	Cer.	Fixed			281-525
C6444		22 $\mu\mu$ f	Cer.	Fixed	500 v		281-511
C6451		198 $\mu\mu$ f	Cer.	Fixed	500 v	10%	281-560
C6457		.02 μ f	Cer.	Fixed	150 v		283-004
C6460		.01 μ f	Mylar	Fixed	500 v	5%	291-019
C6462A		200 $\mu\mu$ f	Mica	Fixed	500 v	1%	283-552
C6462B		500 $\mu\mu$ f	Mica	Fixed	500 v	1%	283-553
C6462C		1000 $\mu\mu$ f	Mica	Fixed	500 v	1%	283-554
C6462D		2000 $\mu\mu$ f	Mica	Fixed	500 v	1%	283-555
C6465		.01 μ f	Cer.	Fixed	500 v		283-002
C6476		.01 μ f	Cer.	Fixed	150 v		283-003
C6480		2000 μ f	EMC	Fixed	30 v		290-087
C6483		.1 μ f	Cer.	Fixed	100 v		283-012
C6487		100 μ f	EMT	Fixed	25 v		290-015
C6488		.01 μ f	Cer.	Fixed	250 v		283-003
C6490		2000 μ f	EMC	Fixed	30 v		290-087
C6491		2000 μ f	EMC	Fixed	30 v		290-087
C6493		.1 μ f	Cer.	Fixed	100 v		283-012
C6495		.1 μ f	Cer.	Fixed	100 v		283-012
C6497		100 μ f	EMT	Fixed	25 v		290-015
C6498		.01 μ f	Cer.	Fixed	150 v		283-003

Inductors

LR5408		2.2 μ h on 47 Ω res. with 39 $\mu\mu$ f Cer. cap.					108-203
LR5477	141-up	0.13 μ h		Fixed			108-006
L5498		29 μ h		Fixed			108-016
L6432		1 mh		Fixed			108-205

Resistors

R5400		18 k	1/4 w	Fixed	Comp.	10%	316-183
R5401		1 k	1/4 w	Fixed	Comp.	10%	316-102
R5403	221-up	200 Ω		Var.	Comp.		311-004
R5404		1.8 k	1/4 w	Fixed	Comp.	10%	316-182
R5405		22 Ω	1/2 w	Fixed	Comp.	10%	302-220
R5406		10 k	1/2 w	Fixed	Comp.	10%	302-203

Resistors (continued)

Tektronix
Part Number

R5407		20 k		Var.	Comp.	10%	311-159
R5410		390 Ω	$\frac{1}{2}$ w	Fixed	Comp.	5%	301-391
R5412		10 Ω	$\frac{1}{10}$ w	Fixed	Comp.	5%	317-100
R5414		10 Ω	$\frac{1}{10}$ w	Fixed	Comp.	5%	317-100
R5416		51 Ω	$\frac{1}{4}$ w	Fixed	Comp.	5%	315-510
R5417		51 Ω	$\frac{1}{4}$ w	Fixed	Comp.	5%	315-510
R5420A	101-350	840 Ω	$\frac{1}{2}$ w	Fixed	Prec.	2%	309-084
R5420A	351-up	845 Ω	$\frac{1}{2}$ w	Fixed	Prec.	1%	309-315
R5420B		610 Ω	$\frac{1}{2}$ w	Fixed	Prec.	1%	309-113
R5420C		500 Ω	$\frac{1}{2}$ w	Fixed	Prec.	1%	309-179
R5420D		484 Ω	$\frac{1}{2}$ w	Fixed	Prec.	1%	309-222
R5420E		20 Ω	$\frac{1}{10}$ w	Fixed	Comp.	5%	317-200
R5421A,B		5 k x 250 Ω		Var.			311-180
R5421C		3.9 k	$\frac{1}{2}$ w	Fixed	Comp.	5%	301-392
R5422A		5 k	$\frac{1}{2}$ w	Fixed	Comp.	10%	309-159
R5422B		20.83 k	$\frac{1}{2}$ w	Fixed	Prec.	1%	309-245
R5422C		26.67 k	$\frac{1}{2}$ w	Fixed	Prec.	1%	309-107
R5422D		820 k	$\frac{1}{4}$ w	Fixed	Comp.	10%	316-824
R5422E		820 k	$\frac{1}{4}$ w	Fixed	Comp.	10%	316-824
R5423		5 k	$\frac{1}{2}$ w	Fixed	Prec.	1%	309-159
R5425		115 Ω	$\frac{1}{2}$ w	Fixed	Prec.	1%	309-281
R5426A		2.5 k	$\frac{1}{2}$ w	Fixed	Prec.	1%	309-181
R5426B				Selected			
R5427		1.8 k	$\frac{1}{4}$ w	Fixed	Comp.	10%	316-182
R5428		33 k	1 w	Fixed	Comp.	10%	304-333
R5430		30 k	$\frac{1}{2}$ w	Fixed	Comp.	5%	301-303
R5431		10 k		Var.	WW		311-015
R5432		15 k	5 w	Fixed	WW	5%	308-108
R5433		3.33 k	$\frac{1}{2}$ w	Fixed	Prec.	1%	309-283
R5434		30 Ω	$\frac{1}{10}$ w	Fixed	Comp.	5%	317-300
R5435		30 Ω	$\frac{1}{10}$ w	Fixed	Comp.	5%	317-300
R5437		62 k	$\frac{1}{2}$ w	Fixed	Comp.	5%	301-623
R5440		150 Ω	$\frac{1}{4}$ w	Fixed	Comp.	10%	316-151
R5442		250 k		Var.	Comp.		311-032
R5443		39 k	$\frac{1}{2}$ w	Fixed	Comp.	5%	301-393
R5446		4.7 k	$\frac{1}{4}$ w	Fixed	Comp.	10%	316-472
R5447		100 k	.2 w	Var.	Comp.	20%	311-088
R5451		390 Ω	$\frac{1}{2}$ w	Fixed	Comp.	5%	301-391
R5452		22 Ω	1 w	Fixed	Comp.	10%	304-220
R5454		2.7 k	$\frac{1}{2}$ w	Fixed	Comp.	10%	302-272
R5455		39 Ω	$\frac{1}{2}$ w	Fixed	Comp.	10%	302-390
R5456		39 Ω	$\frac{1}{2}$ w	Fixed	Comp.	10%	302-390
R5457	101-350	390 Ω	$\frac{1}{2}$ w	Fixed	Comp.	5%	301-391
R5457	351-up	2 k	$\frac{1}{2}$ w	Fixed	Comp.	5%	301-202
R5458		2.7 k	$\frac{1}{2}$ w	Fixed	Comp.	10%	302-272
R5460		22 Ω	1 w	Fixed	Comp.	10%	304-220
R5461		100 Ω	$\frac{1}{4}$ w	Fixed	Comp.	10%	316-101
R5463		120 Ω	$\frac{1}{2}$ w	Fixed	Comp.	10%	302-121
R5464		2.2 k	$\frac{1}{2}$ w	Fixed	Comp.	10%	302-222
R5466		470 Ω	$\frac{1}{2}$ w	Fixed	Comp.	10%	302-471
R5467		500 Ω		Var.	Comp.		311-066
R5468		470 Ω	$\frac{1}{2}$ w	Fixed	Comp.	10%	302-471
R5470		5.03 k	$\frac{1}{2}$ w	Fixed	Prec.	1%	309-134
R5471		5.03 k	$\frac{1}{2}$ w	Fixed	Prec.	1%	309-134

Resistors (continued)

							Tektronix Part Number
R5472		500 Ω		Var.	Comp.		311-005
R5473		400 Ω	$\frac{1}{2}$ w	Fixed	Prec.	$\frac{1}{4}$ %	309-186
R5475		500 Ω	$\frac{1}{8}$ w	Fixed	Prec.	1 %	318-037
R5477A	101-350	150 Ω	$\frac{1}{4}$ w	Fixed	Comp.	5 %	315-151
R5477A	351-up	150 Ω	$\frac{1}{8}$ w	Fixed	Prec.	1 %	318-050
R5477B	101-350	150 Ω	$\frac{1}{4}$ w	Fixed	Comp.	5 %	315-151
R5477B	351-up	150 Ω	$\frac{1}{8}$ w	Fixed	Prec.	1 %	318-050
R5478	101-350	100 Ω	$\frac{1}{4}$ w	Fixed	Comp.	5 %	315-101
R5478	351-up	100 Ω	$\frac{1}{8}$ w	Fixed	Prec.	1 %	318-040
R5479A	101-350	100 Ω	$\frac{1}{4}$ w	Fixed	Comp.	5 %	315-101
R5479A	351-up	100 Ω	$\frac{1}{8}$ w	Fixed	Prec.	1 %	318-040
R5479B	101-350	100 Ω	$\frac{1}{4}$ w	Fixed	Comp.	5 %	315-101
R5479B	351-up	100 Ω	$\frac{1}{8}$ w	Fixed	Prec.	1 %	318-040
R5480		10.1 k	$\frac{1}{8}$ w	Fixed	Prec.	1 %	318-009
R5482		25 k	$\frac{1}{8}$ w	Fixed	Prec.	1 %	318-012
R5484		10.1 k	$\frac{1}{8}$ w	Fixed	Prec.	1 %	318-009
R5485		34 k	$\frac{1}{8}$ w	Fixed	Prec.	1 %	318-036
R5490		2.51 k	$\frac{1}{2}$ w	Fixed	Prec.	1 %	309-133
R5491	101-350	820 Ω	$\frac{1}{4}$ w	Fixed	Comp.	5 %	315-821
R5491	351-up	825 Ω	$\frac{1}{8}$ w	Fixed	Prec.	1 %	318-042
R5493		100 Ω	$\frac{1}{2}$ w	Fixed	Comp.	10 %	302-101
R5495		20 k	$\frac{1}{2}$ w	Fixed	Prec.	1 %	309-153
R5496		10.1 k	$\frac{1}{8}$ w	Fixed	Prec.	1 %	318-009
R5497		1.48 k	$\frac{1}{2}$ w	Fixed	Prec.	2 %	309-028
R5498		1 k	$\frac{1}{2}$ w	Fixed	Prec.	1 %	309-115
R6401		330 k	$\frac{1}{4}$ w	Fixed	Comp.	10 %	316-334
R6403		10 k	$\frac{1}{2}$ w	Fixed	Comp.	5 %	301-103
R6404	101-350	1.6 k	$\frac{1}{4}$ w	Fixed	Comp.	5 %	315-162
R6404	351-up	1.62 k	$\frac{1}{8}$ w	Fixed	Prec.	1 %	318-043
R6405		5 k		Var.	Comp.	10 %	311-171
R6406		6.8 k	$\frac{1}{4}$ w	Fixed	Comp.	10 %	316-682
R6407		10.1 k	$\frac{1}{8}$ w	Fixed	Comp.	10 %	318-009
R6408		1 k	$\frac{1}{2}$ w	Fixed	Comp.	10 %	302-102
R6409		100 Ω	$\frac{1}{4}$ w	Fixed	Comp.	10 %	316-101
R6412	101-350	2.7 k	$\frac{1}{4}$ w	Fixed	Comp.	5 %	315-272
R6412	351-up	2.67 k	$\frac{1}{8}$ w	Fixed	Prec.	1 %	318-044
R6413		5.1 k	$\frac{1}{2}$ w	Fixed	Comp.	5 %	301-512
R6414		5 k		Var.	Comp.	10 %	311-171
R6415		10 k	$\frac{1}{4}$ w	Fixed	Comp.	10 %	316-103
R6416		39 k	$\frac{1}{4}$ w	Fixed	Comp.	10 %	316-393
R6417		10.1 k	$\frac{1}{8}$ w	Fixed	Comp.	10 %	318-009
R6418		1 k	$\frac{1}{2}$ w	Fixed	Comp.	10 %	302-102
R6419		100 Ω	$\frac{1}{2}$ w	Fixed	Comp.	10 %	302-101
R6420		100 Ω	$\frac{1}{4}$ w	Fixed	Comp.	10 %	316-101
R6422		470 Ω	$\frac{1}{2}$ w	Fixed	Comp.	10 %	302-471
R6424		5 k		Var.	Comp.	10 %	311-171
R6425		8.2 k	$\frac{1}{4}$ w	Fixed	Comp.	10 %	316-822
R6427	101-350	3.9 k	$\frac{1}{4}$ w	Fixed	Comp.	5 %	315-392

Resistors (continued)

Tektronix
Part Number

R6427	351-up	3.92 k	$\frac{1}{8}$ w	Fixed	Prec.	1%	318-045
R6428		10.1 k	$\frac{1}{8}$ w	Fixed	Comp.	10%	318-009
R6429		1 k	$\frac{1}{2}$ w	Fixed	Comp.	10%	302-102
R6430		18 k	$\frac{1}{4}$ w	Fixed	Comp.	10%	316-183
R6431		1.07 Meg	$\frac{1}{2}$ w	Fixed	Prec.	1%	309-289
R6432		3.3 k	$\frac{1}{2}$ w	Fixed	Comp.	10%	301-332
R6433		1 k	$\frac{1}{2}$ w	Fixed	Comp.	5%	301-102
R6434A		18 k	$\frac{1}{2}$ w	Fixed	Comp.	5%	301-183
R6434B		2 k	$\frac{1}{2}$ w	Fixed	Comp.	5%	301-202
R6435A		82 k	$\frac{1}{2}$ w	Fixed	Prec.	1%	309-043
R6435B		500 k	$\frac{1}{2}$ w	Fixed	Prec.	1%	309-140
R6435C		267 k	$\frac{1}{2}$ w	Fixed	Prec.	1%	309-276
R6435D		100 Ω	$\frac{1}{2}$ w	Fixed	Comp.	10%	302-101
R6437A		82 k	$\frac{1}{2}$ w	Fixed	Prec.	1%	309-043
R6437B		183 k	$\frac{1}{2}$ w	Fixed	Prec.	1%	309-050
R6437C	101-220 221-up	100 Ω	$\frac{1}{2}$ w	Fixed	Comp.	10%	302-101
R6439		7 k	2 w	Var.	Comp.	10%	311-065
R6439		10 k	2 w	Var.	Comp.	10%	311-153
R6441		1 k	$\frac{1}{4}$ w	Fixed	Comp.	10%	316-102
R6442		18 k	$\frac{1}{2}$ w	Fixed	Prec.	1%	309-036
R6443		100 k	$\frac{1}{2}$ w	Fixed	Comp.	10%	302-104
R6444		220 k	$\frac{1}{2}$ w	Fixed	Prec.	1%	309-052
R6445		100 k	$\frac{1}{2}$ w	Fixed	Prec.	1%	309-045
R6446		20 k	$\frac{1}{2}$ w	Fixed	Comp.	5%	301-203
R6447		100 Ω	$\frac{1}{4}$ w	Fixed	Comp.	10%	316-101
R6448		8.2 k	$\frac{1}{2}$ w	Fixed	Comp.	5%	301-822
R6449		200 k	$\frac{1}{2}$ w	Fixed	Comp.	5%	301-204
R6451		43.4 k	$\frac{1}{2}$ w	Fixed	Prec.	1%	309-176
R6452		1.55 Meg	$\frac{1}{2}$ w	Fixed	Prec.	1%	309-018
R6455		100 k	$\frac{1}{2}$ w	Fixed	Comp.	10%	302-104
R6457		390 k	$\frac{1}{2}$ w	Fixed	Comp.	10%	302-394
R6461		1 k	$\frac{1}{4}$ w	Fixed	Comp.	10%	316-102
R6463		220 k	$\frac{1}{2}$ w	Fixed	Comp.	10%	302-224
R6465		560 k	$\frac{1}{2}$ w	Fixed	Comp.	10%	302-564
R6466		47 k	$\frac{1}{2}$ w	Fixed	Comp.	10%	302-473
R6470		100 Ω	$\frac{1}{4}$ w	Fixed	Comp.	10%	316-101
R6471		100 Ω	$\frac{1}{4}$ w	Fixed	Comp.	10%	316-101
R6472		1 k	$\frac{1}{2}$ w	Fixed	Comp.	10%	302-102
R6473		10 k	1 w	Fixed	Comp.	5%	303-103
R6474		1 k		Var.	Comp.	10%	311-155
R6475		5.6 k	1 w	Fixed	Comp.	5%	303-562
R6476		10 k	$\frac{1}{4}$ w	Fixed	Comp.	10%	316-103
R6477		10 k	$\frac{1}{4}$ w	Fixed	Comp.	10%	316-103
R6478		1 k	$\frac{1}{4}$ w	Fixed	Comp.	10%	316-102
R6479		75 k	$\frac{1}{2}$ w	Fixed	Comp.	5%	301-753
R6482		80 k	$\frac{1}{2}$ w	Fixed	Prec.	1%	309-108
R6483		20 k	$\frac{1}{2}$ w	Fixed	Prec.	1%	309-153
R6484		220 k	$\frac{1}{2}$ w	Fixed	Comp.	10%	302-224
R6486		15 k	1 w	Fixed	Comp.	10%	304-153
R6492		52.6 k	$\frac{1}{2}$ w	Fixed	Prec.	1%	309-137

Resistors (continued)

						Tektronix Part Number	
R6493		10.1 k	1/2 w	Fixed	Prec.	1%	309-034
R6494		220 k	1/2 w	Fixed	Comp.	10%	302-224
R6495		4.7 k	1/2 w	Fixed	Comp.	10%	302-472
R6496		3.3 k	1 w	Fixed	Comp.	10%	304-332

Switches

			Wired	Unwired
SW5420	221-up	Ext. Time Sweep		136-094
SW5422		Nanosec/cm		260-298
SW6462		Samples/Display	262-263	260-299

Transformers

T5410		Toroid, Trifilar, 5T	120-154
T5430		Toroid, Trifilar, 3T	120-166
T5450		Toroid, Trifilar, 12T	120-159
T5460	101-350	Toroid, Trifilar, 7T	120-159
T5460	351-up	Toroid, Trifilar, 12T	120-190
T6480		Power	120-149

Diodes

D5400		Germanium, Q6-100	152-026
D5401		Zener, 15 V 1 W, 1M-15Z5	152-024
D5402		Germanium, Q6-100	152-026
D5403		Germanium, T12G	152-008
D5405		Germanium, DR746	152-007
D5410		Germanium, DR746	152-007
D5412		Germanium, DR746	152-007
D5413		Germanium, DR746	152-007
D5416		Germanium, Q6-100	152-026
D5424		Germanium, DR746	152-007
D5428		Zener, 15 V 1 W, 1M-15Z5	152-024
D5429		Germanium, T12G	152-008
D5434		Germanium, DR746	152-007
D5438		Germanium, DR746	152-007
D5454		Germanium, T12G	152-008
D5455		Germanium, T12G	152-008
D5456		Germanium, T12G	152-008
D5458		Germanium, T12G	152-008
D5461		Germanium, T12G	152-008
D5464		Germanium, T12G	152-008
D5480		Selected	153-002
D6400		Germanium, DR746	152-007
D6401		Germanium, DR746	152-007
D6426		Germanium, DR746	152-007
D6430		Germanium, T12G	152-008
D6462		Germanium, T13G	152-005
D6472		Zener, 25 V 1 W, 1M25Z5	152-022
D6473		Germanium, 1N-634	152-025
D6481		Silicon, 400 V PIV 500 MA	152-011
D6482		Silicon, 400 V PIV 500 MA	152-011
D6491		Silicon, 400 V PIV 500 MA	152-011
D6492		Silicon, 400 V PIV 500 MA	152-011

Transistors

		Tektronix Part Number
Q5410	SM-04/2N695	151-032
Q5423	2N1381	151-039
Q5424	2N169A	151-033
Q5430	SM-04/2N695	151-032
Q5444	2N636 Pre-Selected	151-038
Q5450	2N597/2N658	151-021
Q5460	2N601	151-036
Q5464	2N597/2N658	151-021
Q5484	2N700	151-027
Q5493	OC170	151-015
Q5494	OC170	151-015
Q6403	OC170	151-015
Q6404	OC170	151-015
Q6414	OC170	151-015
Q6424	OC170	151-015
Q6432	2N169A	151-033
Q6444	OC170	153-511
Q6483	2N270	151-007
Q6484	2N544	151-008
Q6487	2N301	151-001
Q6493	2N270	151-007
Q6494	2N544	151-008
Q6497	2N301	151-001

Selected, 75 v minimum, collector current 50 μ a

Electron Tubes

V6432A,B	12AL5	154-038
V6445A,B	6AN8	154-078
V6452A,B	12AL5	154-038
V6453A,B	12AT7	154-039
V6461	12AU6	154-040
V6462A,B	12AL5	154-038
V6473	12AU7	154-041

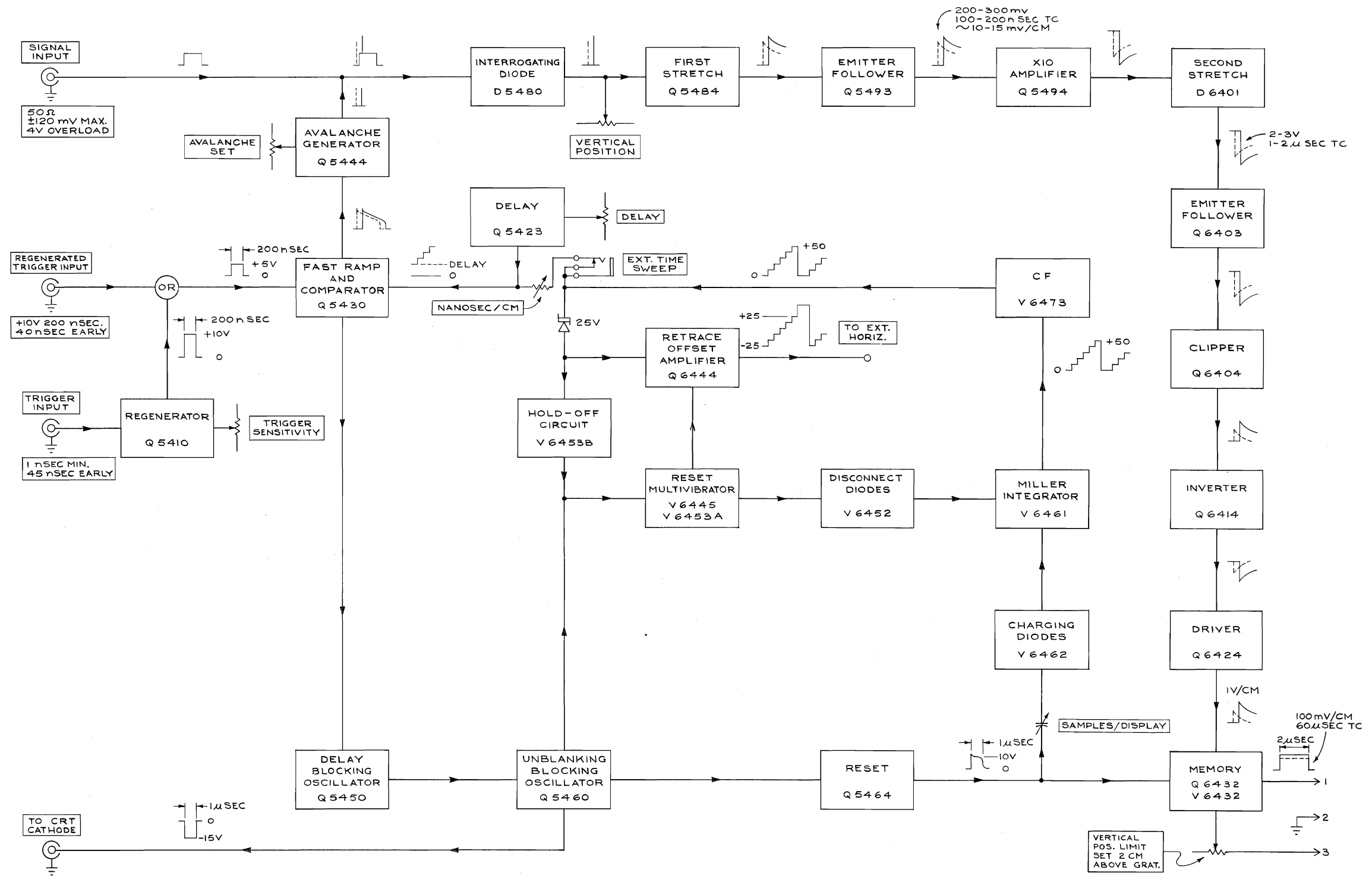

TYPE N PLUG-IN UNIT

B

MRH
4-28-60
BLOCK DIAGRAM

BLOCK DIAGRAM

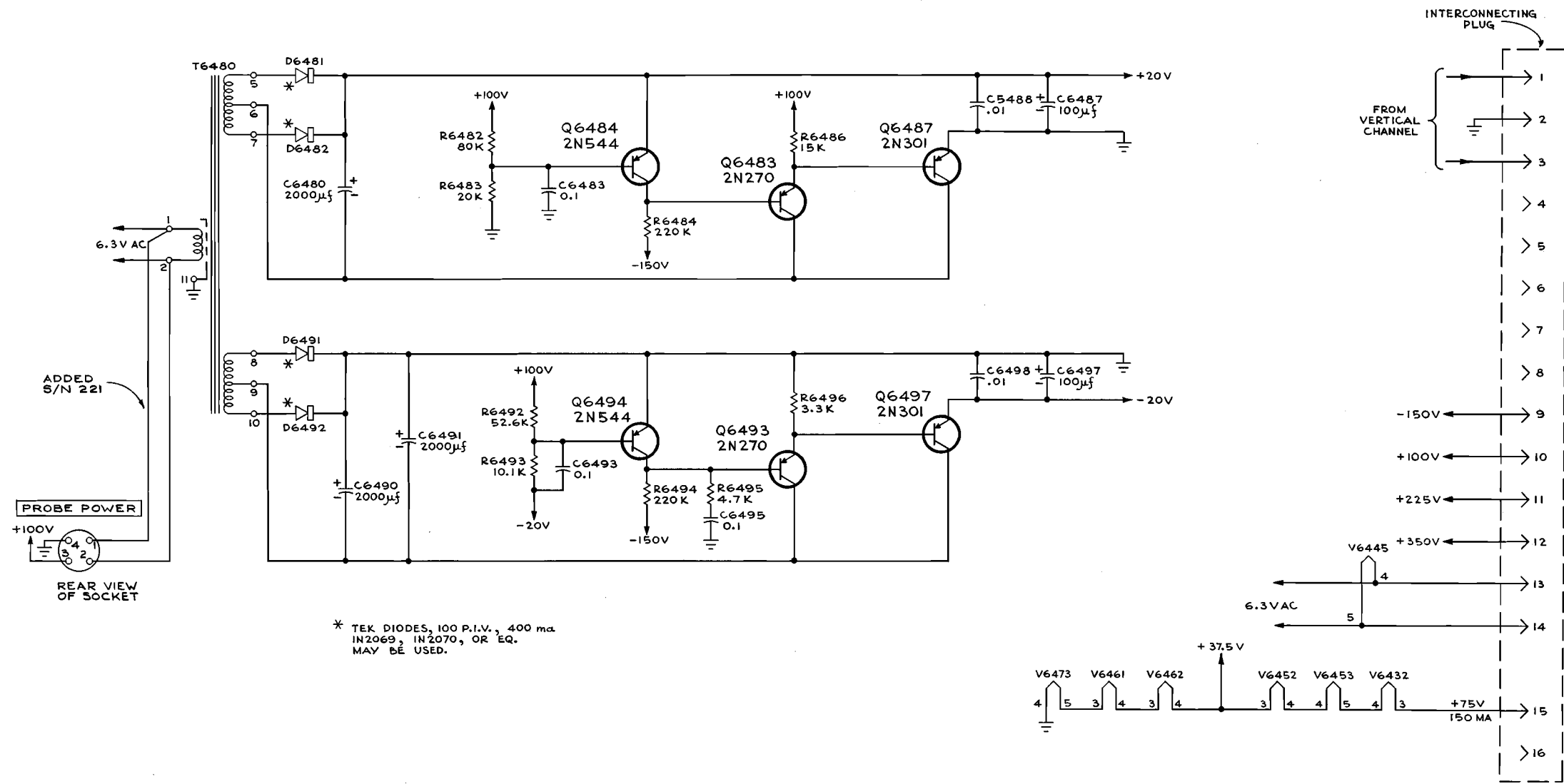

TYPE N PLUG-IN UNIT

B

POWER SUPPLY

4-27-60

POWER SUPPLY

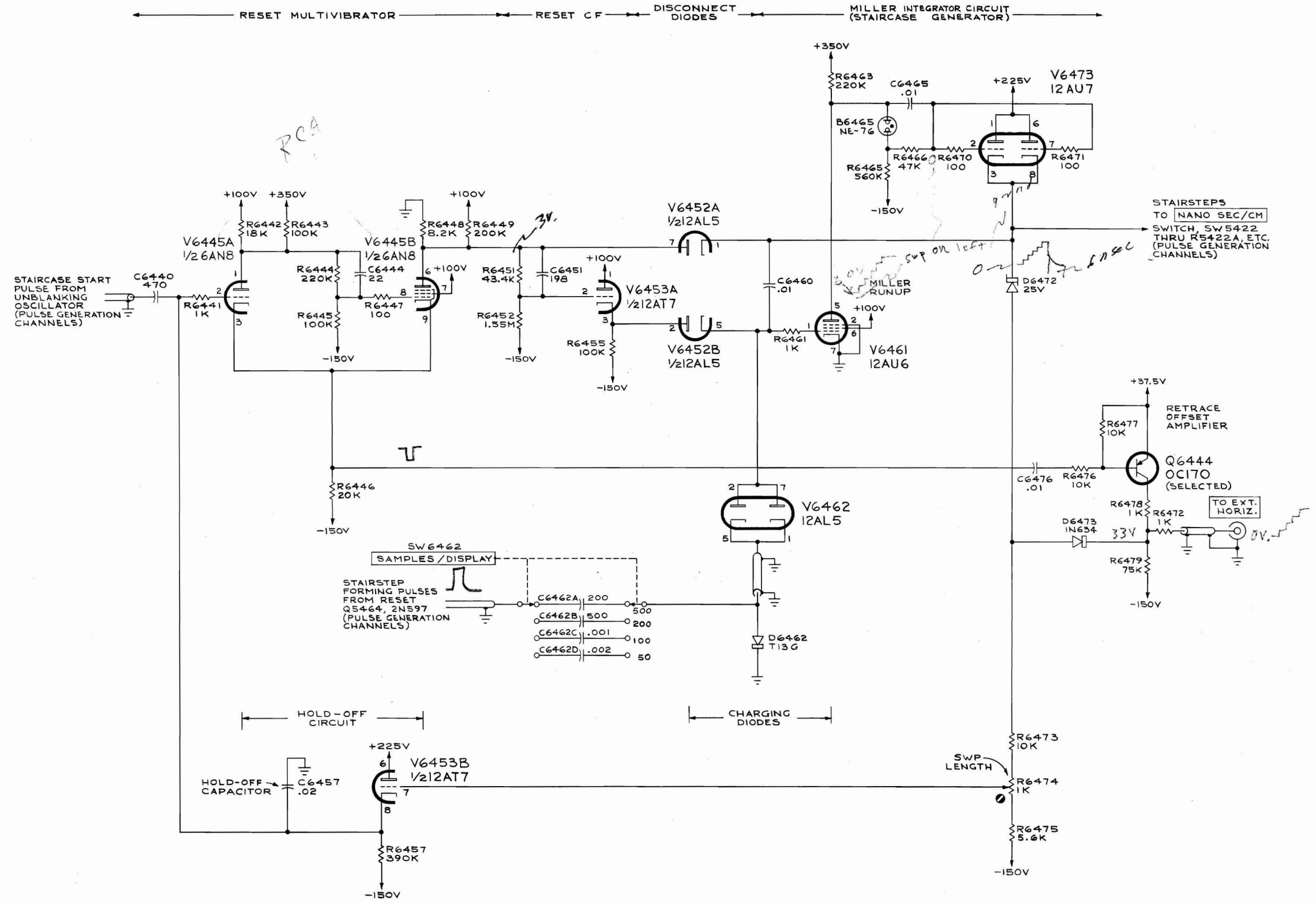

TYPE N PLUG-IN UNIT

A

MRH
12-15-59
HORIZONTAL CHANNEL

SWITCH DETAIL

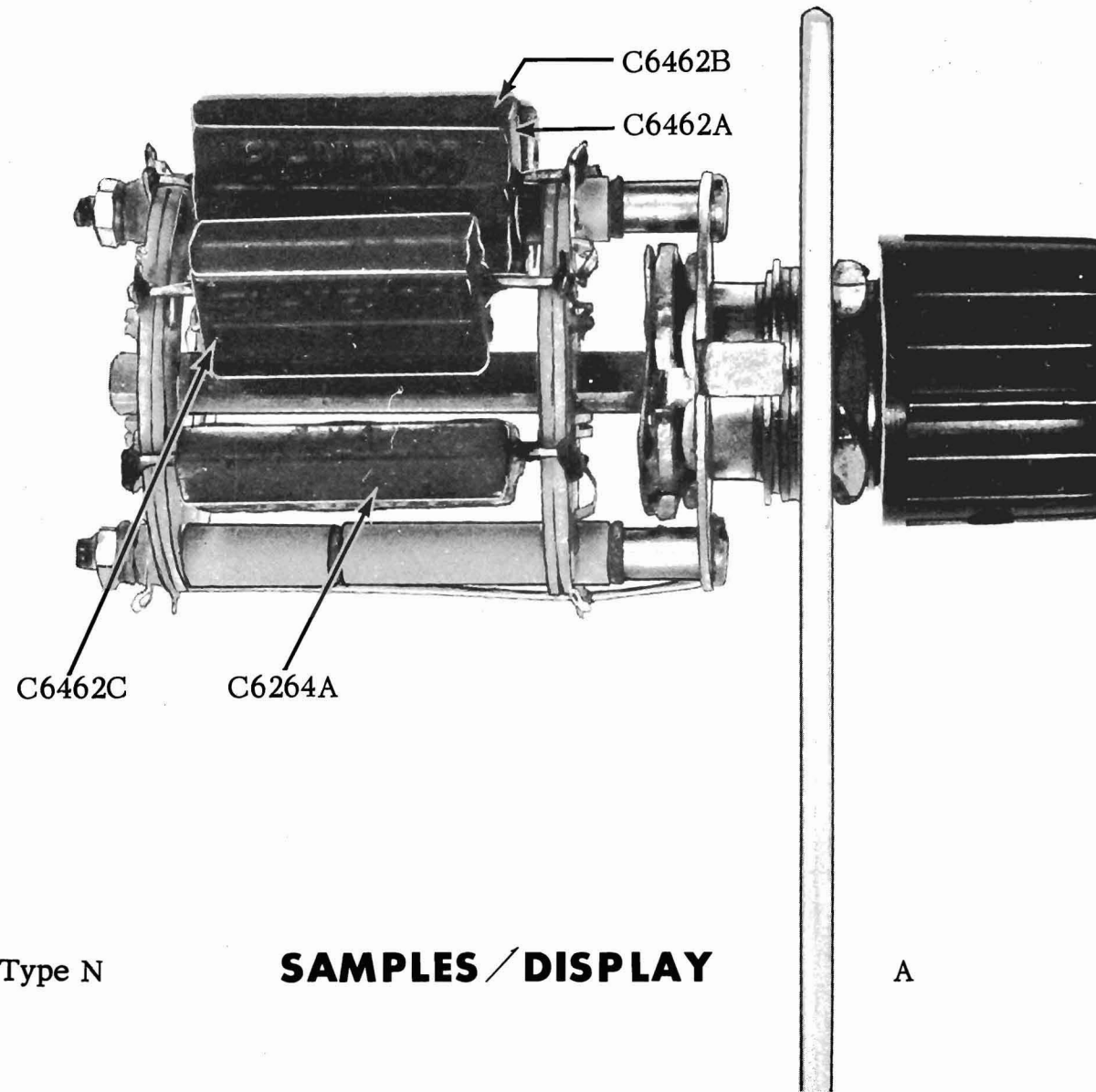

Type N

SAMPLES / DISPLAY

A

HORIZONTAL CHANNEL

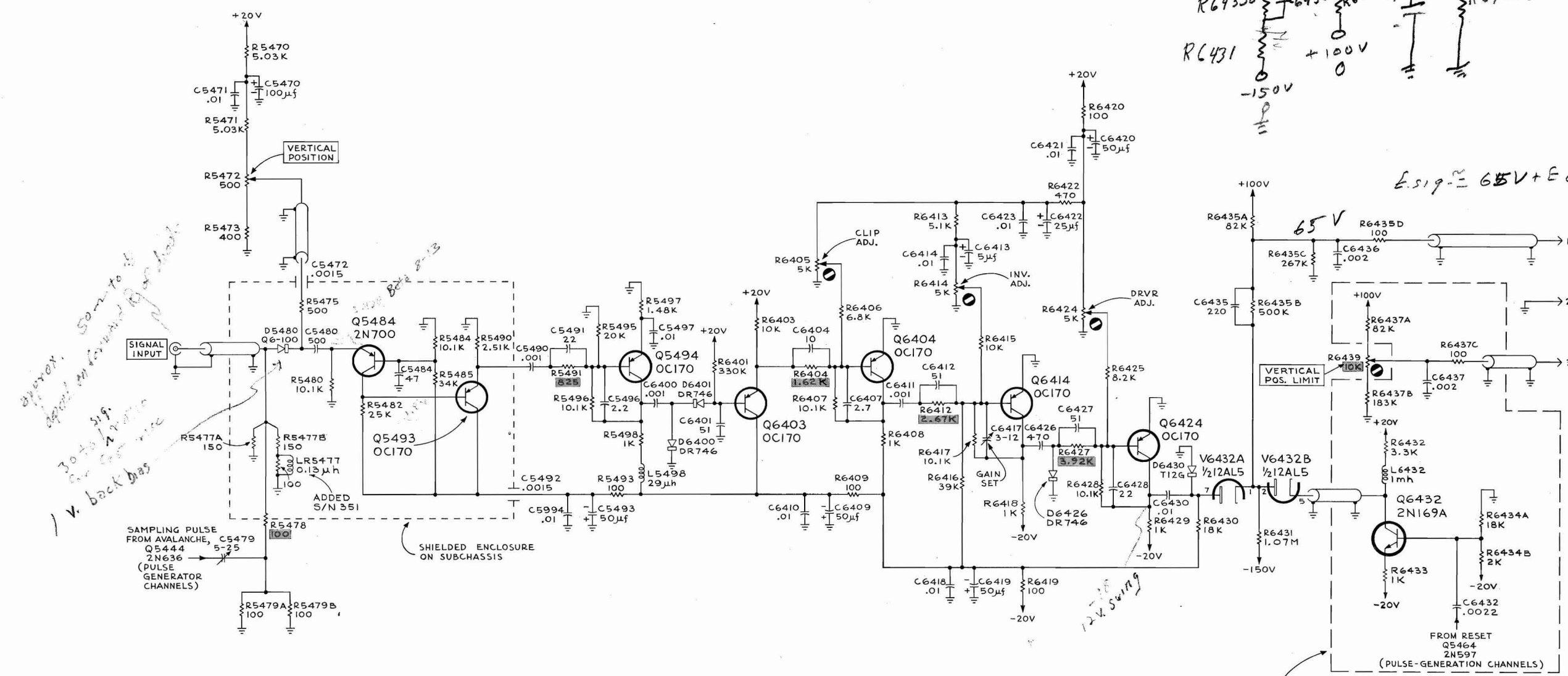

*approx. 50-100
 30 to 40
 1 V. back bias*

TYPE N PLUG-IN UNIT

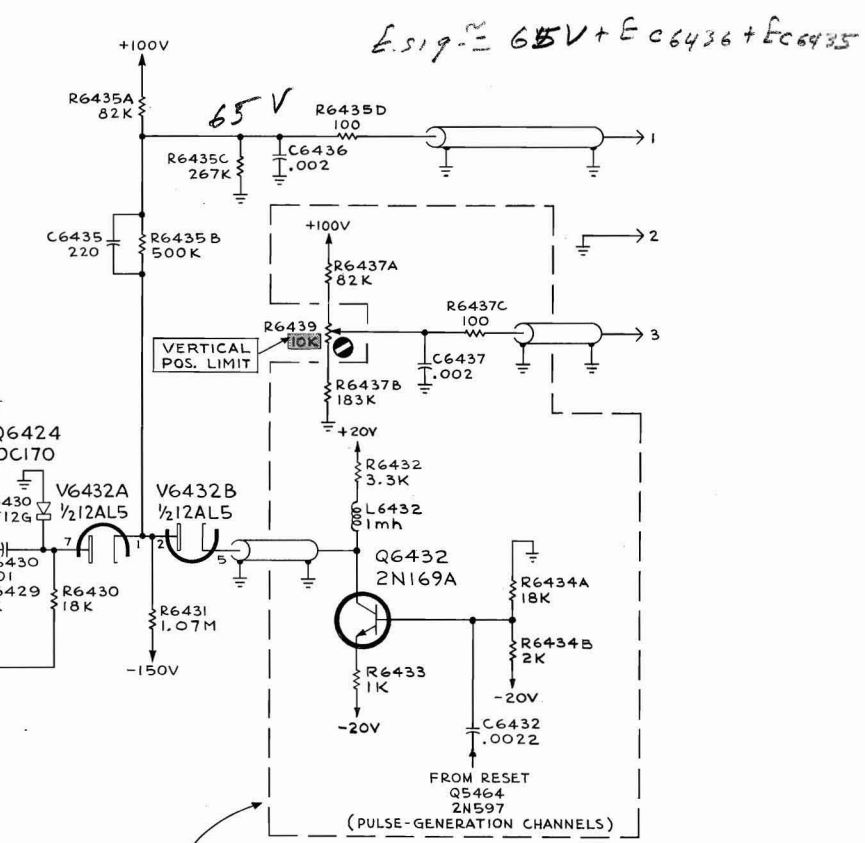
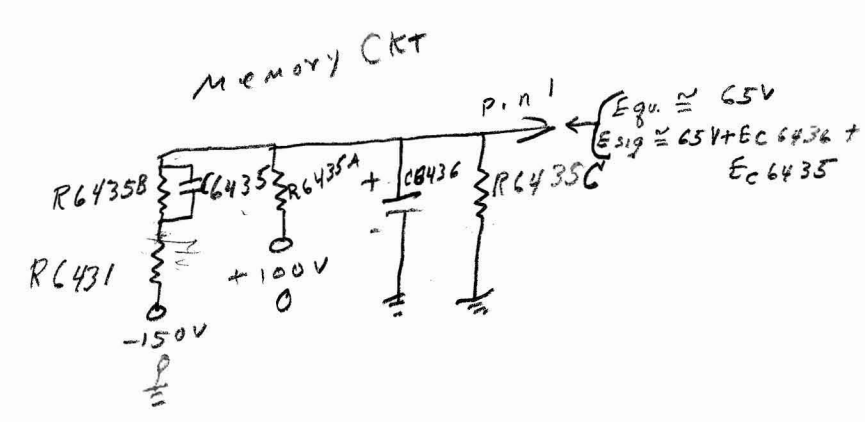

VERTICAL CHANNEL

B

9 & B
 4-27-60

COMPONENTS SHOWN WITHIN OUTLINE ARE LOCATED ON POWER SUPPLY CHASSIS

Sub chas. in vert. must be tightened to $\frac{1}{8}$. (3 screws.)
causes \sim should be \sim base line shifts when varying
delay pot.

VERTICAL CHANNEL



High plus +20 causes vert. shift

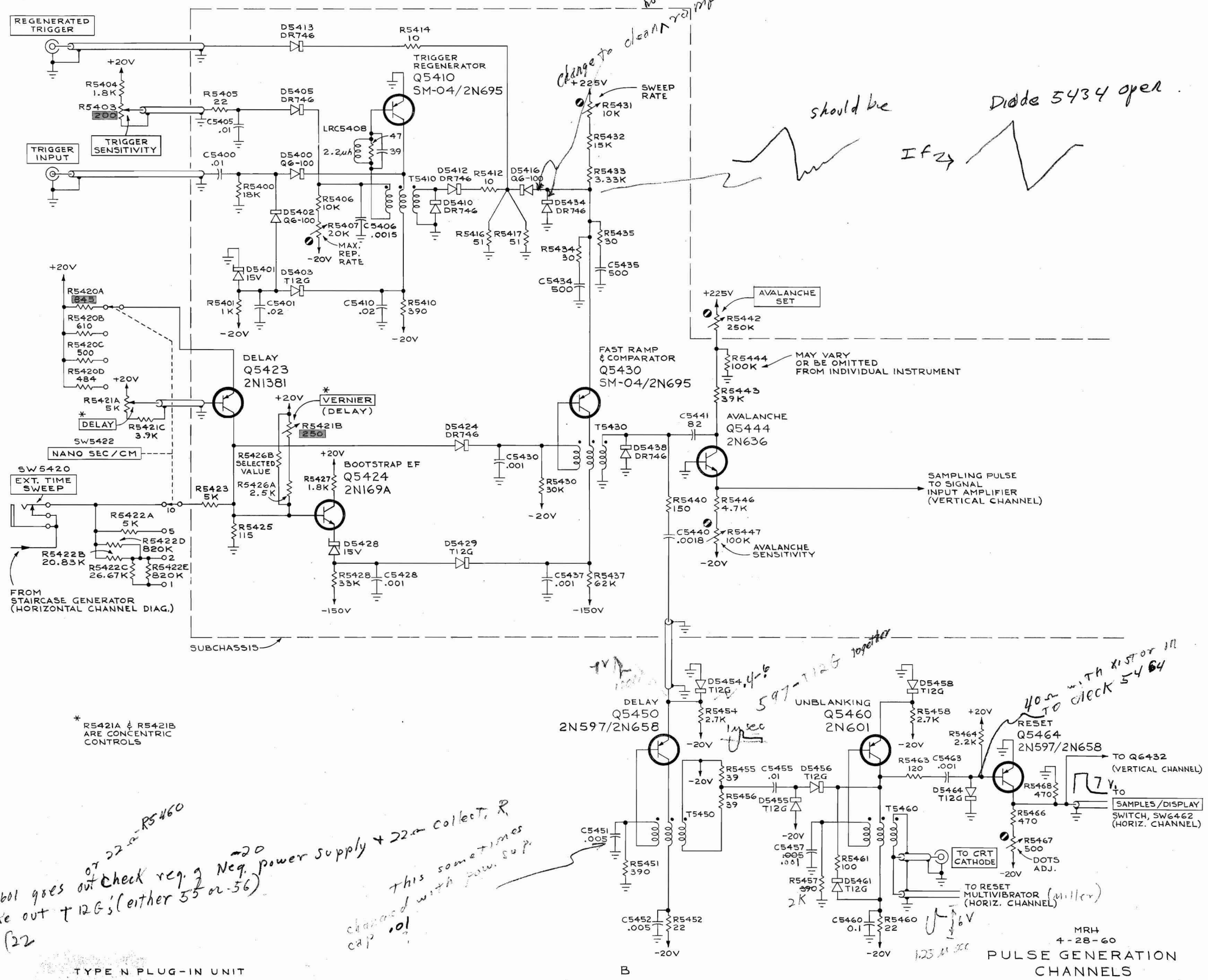

- 20
- 1 IF 2N601 goes out check req. 2 Neg. power supply +22m collect. R
- 2 will take out 12G's (either 55 or 56)
- 3 R5452 (22)
- * R5421A & R5421B ARE CONCENTRIC CONTROLS
- * R5421A & R5421B ARE CONCENTRIC CONTROLS
- * R5421A & R5421B ARE CONCENTRIC CONTROLS

TYPE N PLUG-IN UNIT

B

MRH 4-28-60 PULSE GENERATION CHANNELS

PULSE GENERATION CHANNELS

SWITCH DETAIL 

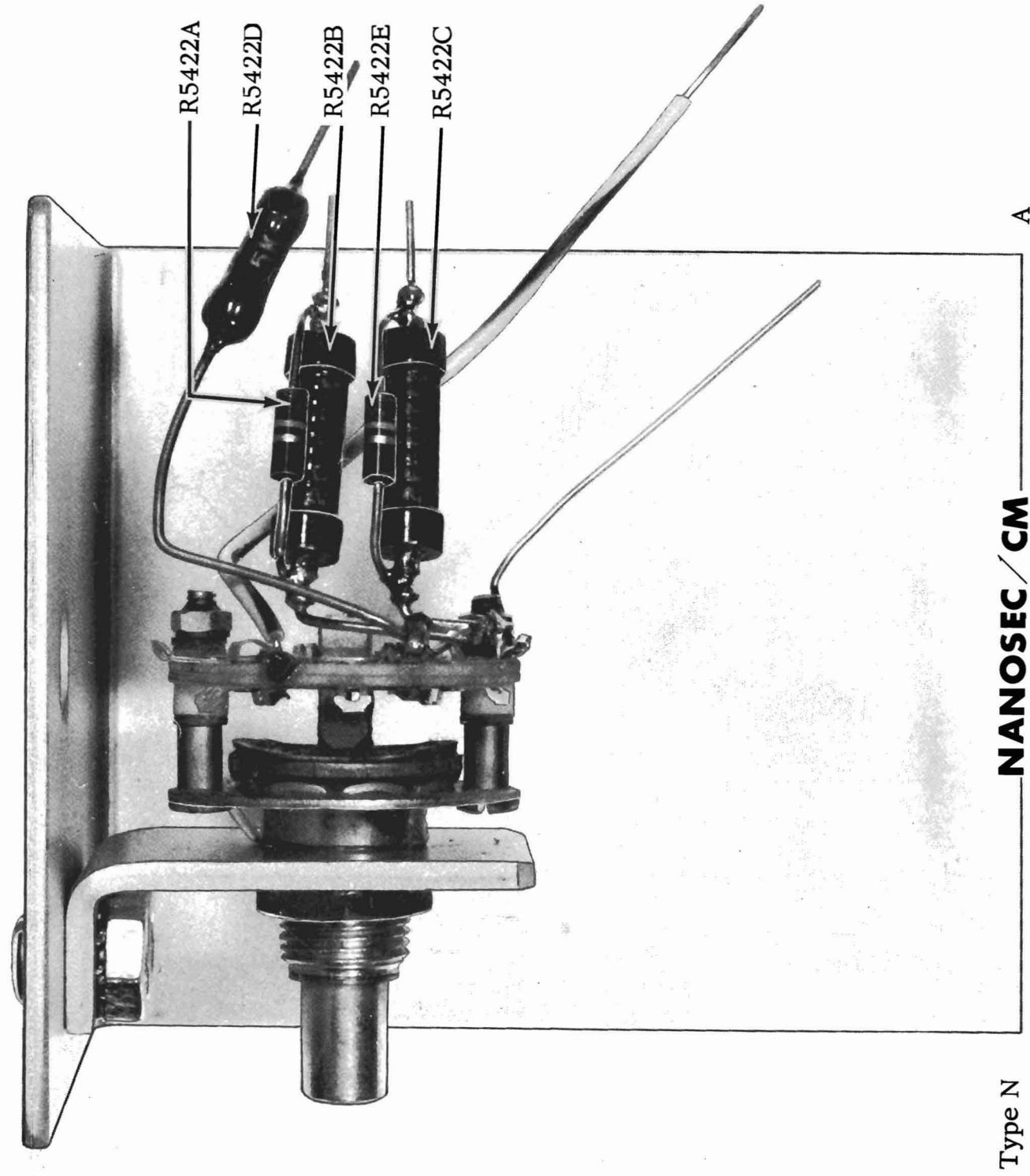

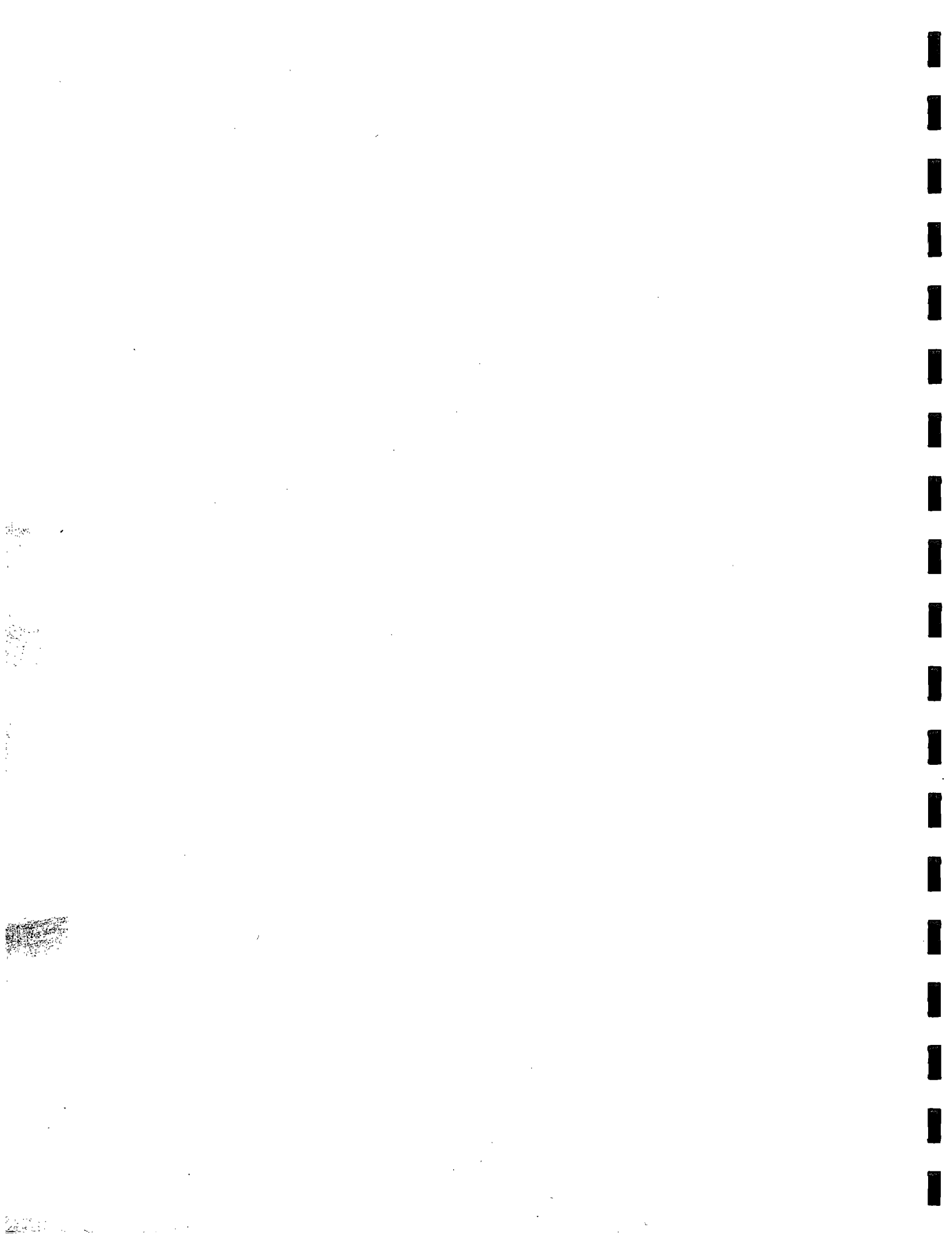

Rotate the 105 FREQUENCY control from 50 to 120 kc and check to see that the pedestal does not move over 3 millimeters, that the gain doesn't change over 4%, and that the trace doesn't shift horizontally over 1/2 centimeter.

Check to see that the N Unit is capable of triggering at 50 cps and at 50 mc.

